



MOTORCYCLE UNREGULATED EMISSIONS

27/05/2002

MOTORCYCLE UNREGULATED EMISSIONS

1 INTRODUCTION

ACEM, whose office is situated in the city of Brussels in Belgium, are the Association of European Motorcycle manufacturers. ACEM members include all the major European motorcycle manufacturers, the national motorcycle associations of many EC member states as well as the major motorcycle manufacturers from Japan and North America.

Although a considerable base of expertise exists in member companies in the field of regulated pollutants (CO, HC and NO_x), very little is known about the currently unregulated pollutants that make up smallest fractions of motorcycle exhaust emissions. In 2001, ACEM member companies expressed a wish to explore this important aspect of their products and this report is the result. The main purpose of the report is to expand the collective knowledge of ACEM members in the field of currently unregulated exhaust emissions across a variety of typical motorcycle types.

It should also be noted that this report is the result of a collaborative arrangement, which was made with two knowledgeable and respected external bodies. These are the UK Department for Transport, Local Government and the Regions (DTLR) and Ricardo Consulting Engineers of Shoreham by Sea, UK. ACEM co-operation with DTLR was requested in support of a programme of motorcycle test work which DTLR conducted. ACEM member companies contributed motorcycles for test to the DTLR programme, which was conducted at Ricardo's Shoreham laboratories. The unregulated test data stemming from the DTLR programme was purchased from DTLR by ACEM.

The authors of this report are Dr Renaud Rohe, Paul Etheridge and Jon Andersson from Ricardo.

ACEM wish to point out that the report, analysis of results and opinions expressed are strictly those of ACEM and do not in any way constitute the analysis conclusions or opinions of DTLR.

The report contains seven chapters and three appendices. These are as follows:

- Chapter 1. Introduction.
 - Chapter 2. Emissions of unregulated pollutants.
 - Chapter 3. Comparison of motorcycle emissions with other sectors.
 - Chapter 4. Unregulated emissions reduction techniques.
 - Chapter 5. Health effects of unregulated pollutants.
 - Chapter 6. Potential for future legislation.
 - Chapter 7. ACEM conclusions.
-
- Appendix 1. Test method descriptions.
 - Appendix 2. Regulated emissions report.



Appendix 3. Fuel Specification

Chapter 1. is the current chapter where ACEM explain the reasons for the project and the external bodies involved.

Chapter 2. lists the pollutants measured in the programme, gives a key to each of the test methods and defines the test cycle used. It goes on to show comprehensive details of the test results for the full spectrum of unregulated emissions from each motorcycle.

Chapter 3. draws comparison between motorcycle emissions and those of other sectors of road transport.

Chapter 4. summarises some of the emissions reduction techniques available to motorcycle manufacturers for both regulated and unregulated emissions.

Chapter 5. describes the health and air quality effects of each unregulated pollutant balanced against recommended levels for human health.

Chapter 6. summarises the potential for future legislation on unregulated emissions of motorcycles.

Chapter 7. Provides a summary of ACEM conclusions drawn from the details contained in the body of the report.

ACEM regard the report as a first step in building knowledge of unregulated pollutants within the motorcycle industry. Although the pollutants measured are currently unregulated, ACEM regard knowledge of the subject as an important step in making motorcycling an environmentally friendly mode of transportation. We look forward to furthering knowledge of this subject in the future.

2 EMISSIONS OF UNREGULATED POLLUTANTS

The various classes of components analysed within this programme required the application of several specialised analytical techniques. The compounds analysed and techniques employed are summarised in Table 1.

Analytical methods are described in Appendix 1, with a detailed fuel specification presented in Appendix 3.

Table 1 : Analyses of Unregulated Species

Chemical Name	Formula	Chemical Class	Measurement Technique
Methane	CH ₄	Aliphatic Hydrocarbon	FTIR
1,3-butadiene	C ₄ H ₆	Unsaturated Hydrocarbon	OLMS
Benzene	C ₆ H ₆	Aromatic Hydrocarbon	OLMS
Toluene	C ₇ H ₈	Aromatic Hydrocarbon	OLMS
Xylenes	C ₈ H ₁₀	Aromatic Hydrocarbon	OLMS
Formaldehyde	CH ₂ O	Carbonyl	FTIR
Acetaldehyde	C ₂ H ₅ O	Carbonyl	FTIR
Nitric oxide	NO	Inorganic gas	FTIR
Nitrogen Dioxide	NO ₂	Inorganic gas	FTIR
Nitrous Oxide	N ₂ O	Inorganic gas	FTIR
Ammonia	NH ₃	Inorganic gas	FTIR
Hydrogen Sulphide	H ₂ S	Inorganic gas	OLMS
Sulphur Dioxide	SO ₂	Inorganic gas	OLMS

Chemical Analyses	Technique
Oil hydrocarbons	Gas Chromatography
Fuel hydrocarbons	Gas Chromatography
Sulphates & nitrates	Ion Chromatography
Carbon	Thermogravimetry
Volatile compounds	Thermogravimetry

Physical Analyses	Technique
Particle Number	Condensation Particle Counter
Particle Mass	MOUDI
Mass weighted size distribution	MOUDI

Twelve motorcycles were subjected to the current legislated cycle described in directive 97/24/EC. At the time of conducting the physical tests, changes to the regulated EC emissions test cycle were proposed but not finalised. In order to proceed with the test programme, ACEM selected the 97/24/EC (Figure 1) cycle as use of other alternatives may eventually have been incorrect or invalid.

Figure 1 : 97/24/EC Test Cycle

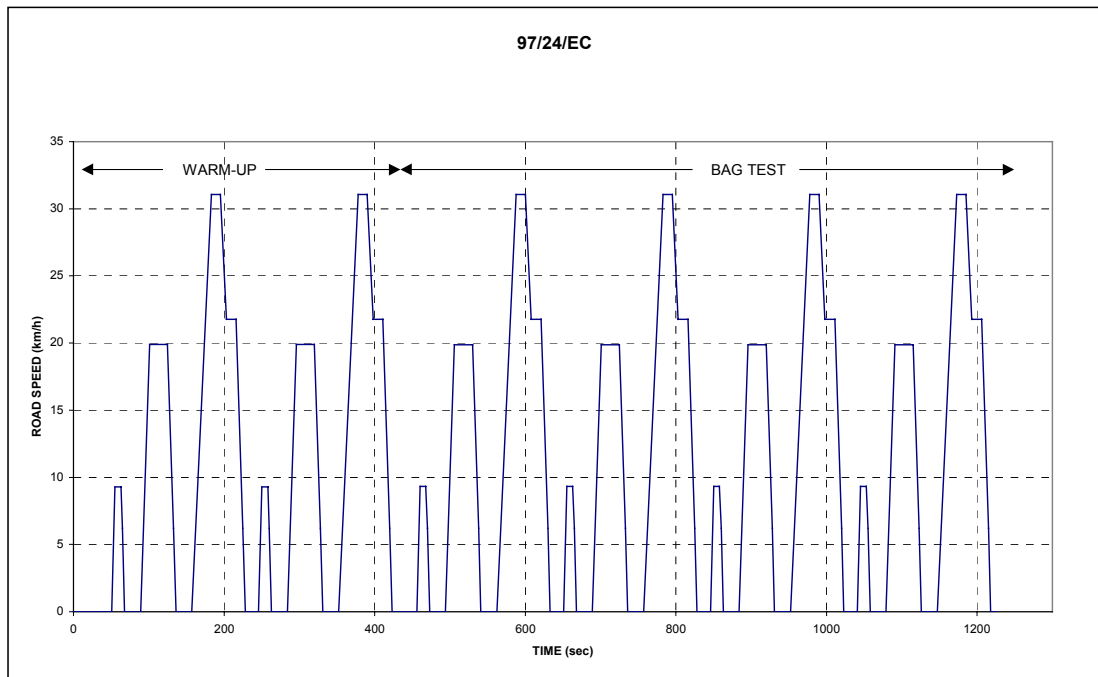

A generic description of the 12 motorcycles is shown in Table 2 below:
Throughout the report, reference to individual motor cycles will be made by the number shown in the left-hand column of Table 2.

Table 2 : Description of Motorcycles

Motorcycle	Approximate Capacity (cc)	2 or 4 Stroke	FUELLING	SAI	CATALYST
BK01	180	4S	Carburettor	No	No
BK02	150	4S	Carburettor	Yes	No
BK03	950	4S	EFi	No	Yes
BK04	800	4S	Carburettor	Yes	Yes
BK05	650	4S	EFi	No	Yes
BK06	500	4S	Carburettor	No	No
BK07	400	4S	Carburettor	Yes	No
BK08	50	2S	EFi	No	No
BK09	1300	4S	EFi	No	Yes
BK10	250	4S	Carburettor	Yes	No
BK11	50	2S	Carburettor	No	Yes
BK12	650	4S	Carburettor	Yes	No

2.1 Real Time Analyses of Gaseous Unregulated Emissions by FTIR and OLMS: Comparison of Motorcycles

Comparisons of unregulated emissions levels from the 12 bikes tested are shown for the 97/24/EC drive cycle in the figures below. Figure one shows emissions from the hydrocarbon species; benzene and 1,3-butadiene plus the most reduced species; hydrogen sulphide and ammonia. Another shows the individual nitrogen oxide species and sulphur dioxide. These charts illustrate average mass emissions (mg) across the cycle per km driven.

Table 3 summarises the unregulated analyses data.

Table 3 : Summarised Unregulated Gaseous Emissions Data (mg/km)

Chemical Compound	Chemical Formula	Bike 01	Bike 02	Bike 03	Bike 04	Bike 05	Bike 06	Bike 07	Bike 08	Bike 09	Bike 10	Bike 11	Bike 12
Benzene	C6H6	43.1	86.8	54.3	13.4	62.8	77.7	27.8	6.3	6.8	41.0	107.2	24.8
1,3-butadiene	C4H6	10.9	5.5	8.2	0.6	9.0	15.6	2.8	1.6	0.7	6.7	17.7	3.5
Xylenes	C8H10	159.4	1250.2	127.5	28.2	109.5	201.1	214.9	72.2	27.6	165.9	1110.0	71.7
C-3 substituted benzenes	C9 arom	142.9	994.2	123.0	25.5	88.7	174.0	128.8	75.0	25.7	131.5	896.4	58.2
Hydrogen Sulphide	H2S	0.1	0.1	0.1	0.0	0.1	0.1	0.1	0.1	0.0	0.1	0.2	0.1
Sulphur Dioxide	SO2	3.3	3.6	0.3	2.3	1.0	3.8	No data	No data	No data	1.5	1.7	5.6
Toluene	C7H8	164.6	1064.2	136.2	29.2	124.7	267.6	152.0	60.9	22.9	147.4	1172.3	87.5
Nitric oxide	NO	No data	No data	34.8	20.2	19.1	60.4	72.2	114.5	15.5	96.3	14.3	92.6
Nitrogen dioxide	NO2	No data	No data	-1.5	0.0	-0.5	-2.6	-1.8	10.9	-0.7	0.6	-6.4	8.9
Nitrous oxide	N2O	No data	No data	-1.1	0.2	0.3	-0.4	-0.3	7.4	-0.5	-0.1	0.0	0.0
Methane	CH4	No data	No data	64.9	31.6	145.8	123.8	32.5	3.7	54.7	51.3	47.6	31.3
Formaldehyde	CH2O	No data	No data	25.6	4.1	8.1	47.7	24.9	18.7	4.7	28.7	61.8	30.0
Acetaldehyde	C2H5O	No data	No data	11.8	0.8	2.9	11.6	-5.5	25.2	0.9	17.9	20.0	15.1
Ammonia	NH3	No data	No data	16.9	24.9	35.8	1.7	1.8	0.6	24.2	1.5	1.8	1.6

Figure 5 and Figure 6 show highly repeatable emissions from triplicate 97/24 cycles. Benzene and 1,3-butadiene emissions trends across the various bikes are similar; lowest emissions can be observed from bikes 4, 7, 8, 9 and 12, with highest emissions levels (benzene; 80 – 100 mg/km, 1,3-butadiene about a fifth of these) consistently from bikes 6 and 11. Although benzene emissions were high from bike 2 relative to the other bikes (~90mg/km), 1,3-butadiene emissions were not similarly elevated (6mg/km).

These observations are consistent with emissions of regulated HCs where high emissions were observed from bikes 2 and 6 – these emissions associated with deceleration overruns. High HC emissions were also observed for the carburetted two-stroke Bike 11, where there was no emissions control and operation was very rich.

Benzene is present in the fuel, and its emissions are also closely associated with other fuel aromatics. High emissions can therefore be observed from both rich combustion and fuel survival. 1,3-butadiene and methane emissions are purely combustion products.

In general, other aromatics; toluene, xylenes and trimethylbenzenes showed emissions levels ~10 times those of benzene but similar trends across the range of bikes. These aromatic classes are the most abundant individual components in gasoline.

Hydrogen sulphide emissions levels were generally low, at less than 0.2mg/km from all bikes. Highest emissions were observed from bike 11, where the very rich operation enabled reduction of the sulphur (derived from the fuel and/or lube) to its lowest oxidation state (Figure 3).

Ammonia emissions were highest from bikes 3, 4 and 9, all of which were equipped with three-way catalysts (TWC). Emissions levels were significant; at 20 to 35mg/km. This suggests a chemical reduction of NO_x species over the three way catalyst to ammonia. The formation of ammonia over three-way catalysts is a well known phenomenon, and can be related to periods of reducing conditions when oxygen is scarce. However, as shown for Bike 3, in Figure 2, transient ammonia production appears to increase and stabilise across the drive cycle.

This suggests that the ammonia may be stored and then released with increasing cycle temperature. This ammonia may be associated with water within in the exhaust system.

Emissions of the other nitrogenous species; NO (nitric oxide), NO₂ (nitrogen dioxide) and N₂O (nitrous oxide) plus SO₂ (sulphur dioxide) are shown in Figure 5, with the product of partial oxidation, formaldehyde, shown in Figure 4

Acetaldehyde emissions trends between bikes were broadly similar to those of formaldehyde. Acetaldehyde emissions (not shown) were ~60% of formaldehyde levels.

Figure 2 : Ammonia Emissions - 97/24/EC Cycle (Bike 3)

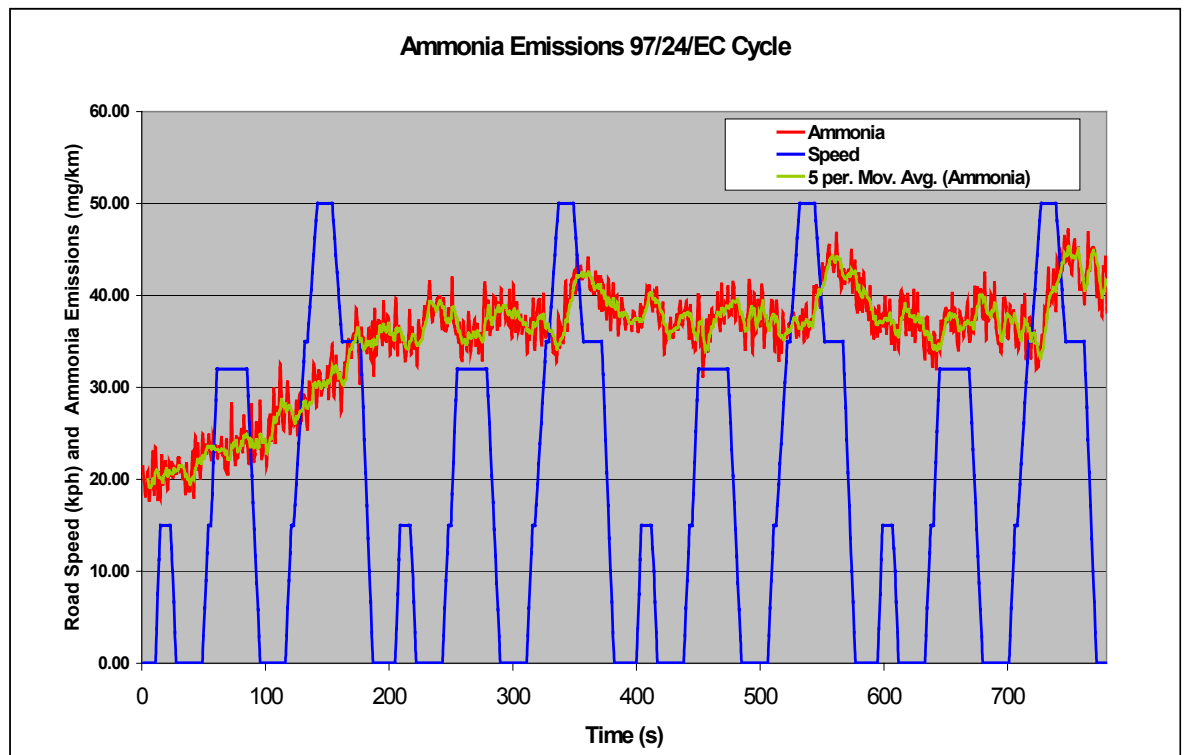

Figure 3 : Hydrogen Sulphide Emissions - 97/24/EC Cycle (Bike 11)

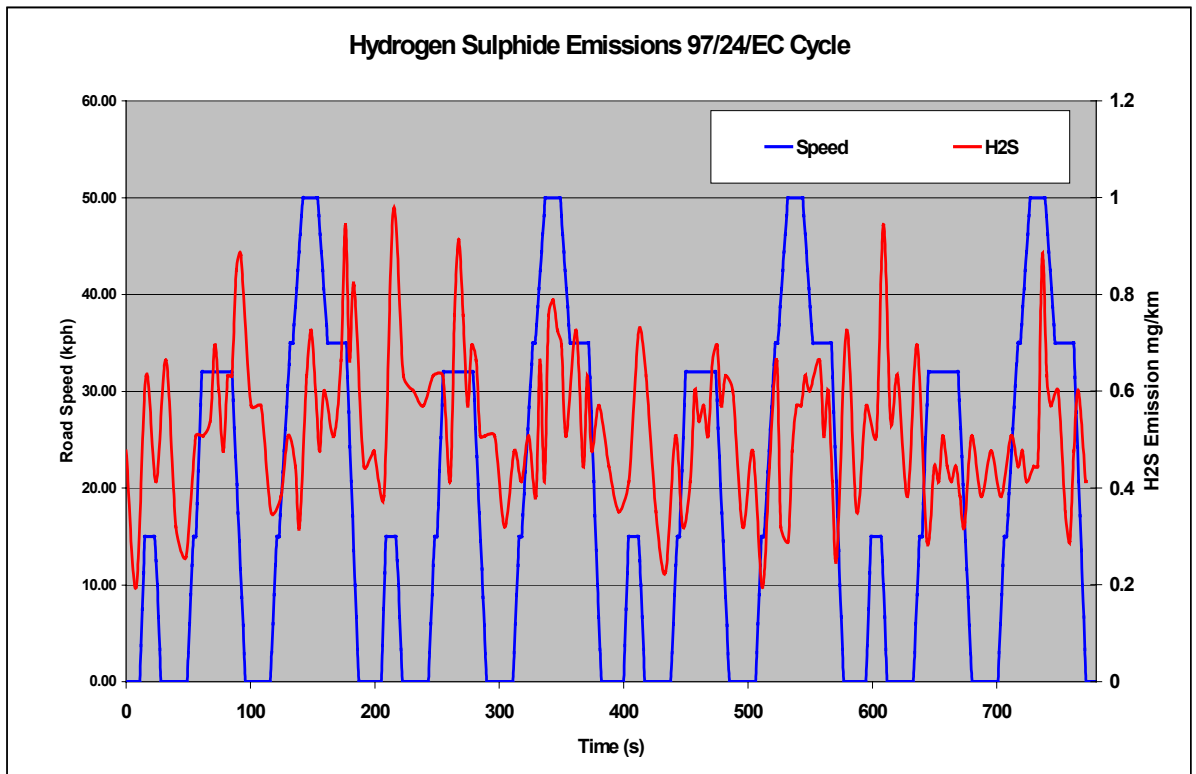

Figure 4 : Unregulated Emissions - Formaldehyde

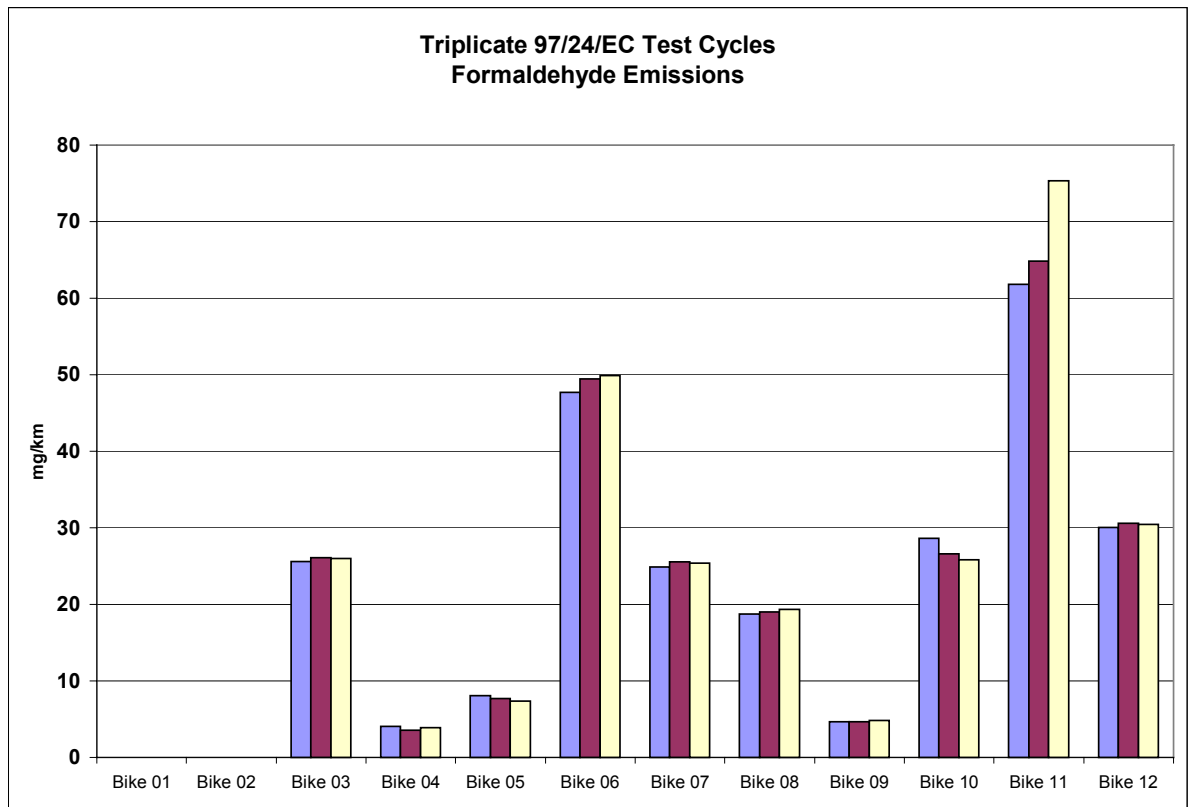

Figure 5 : Unregulated Emissions 97/24/EC Cycles

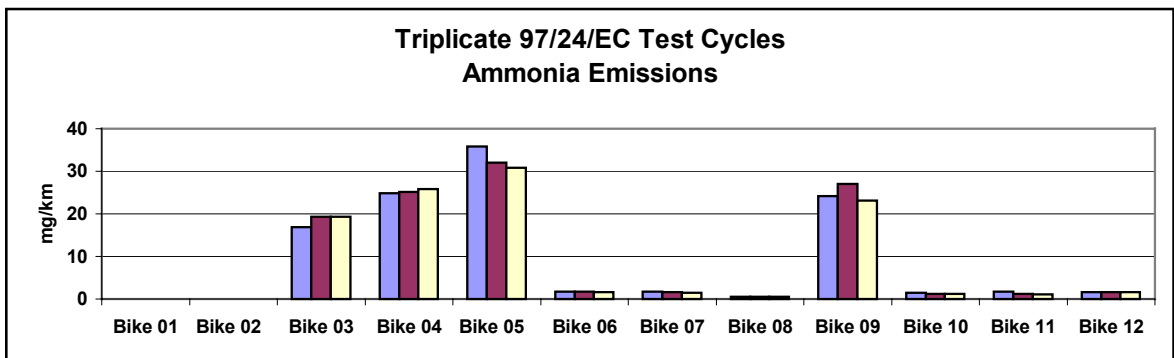
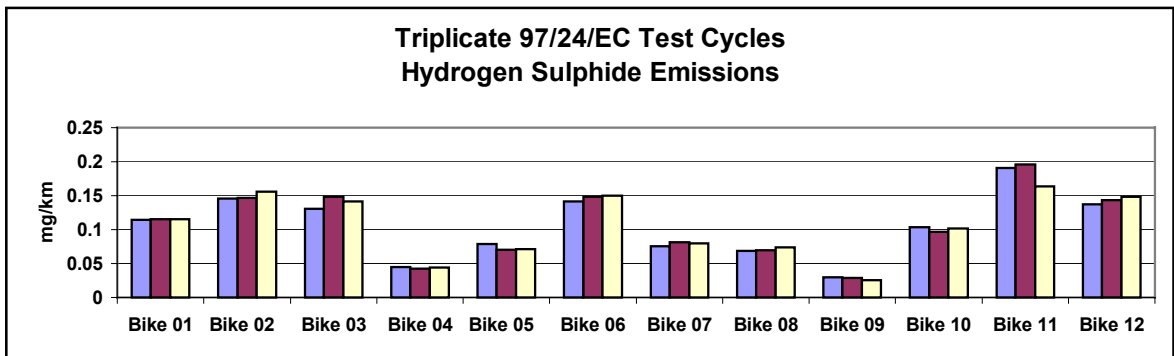
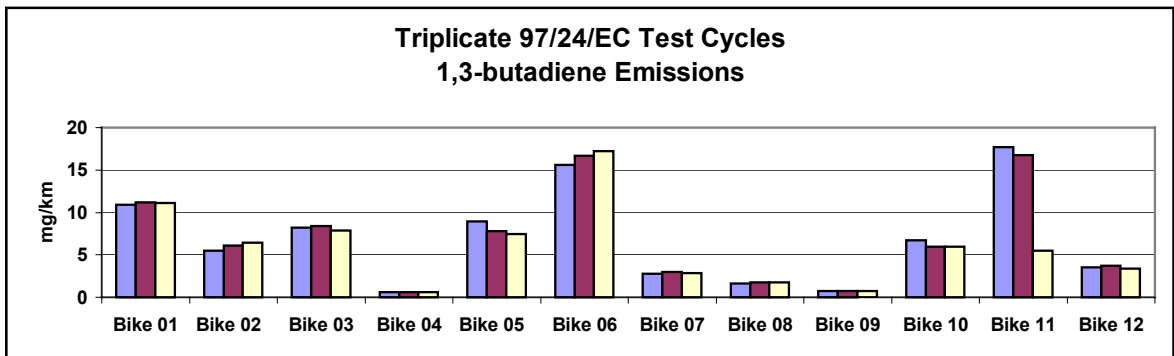
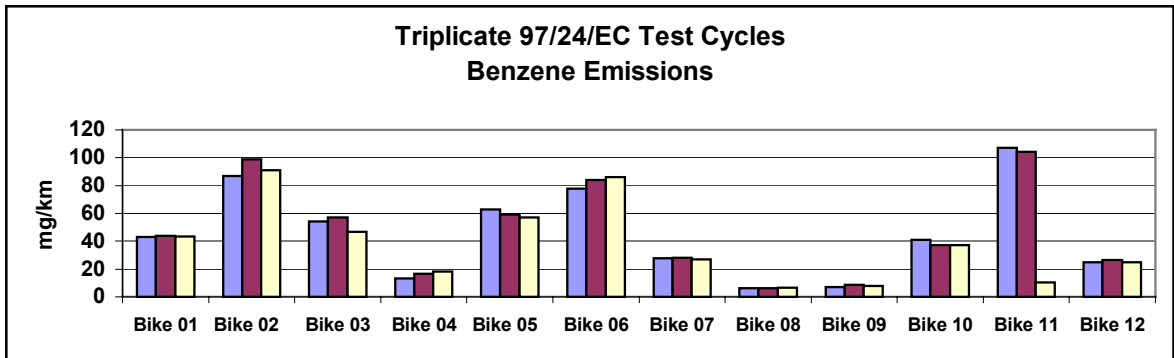
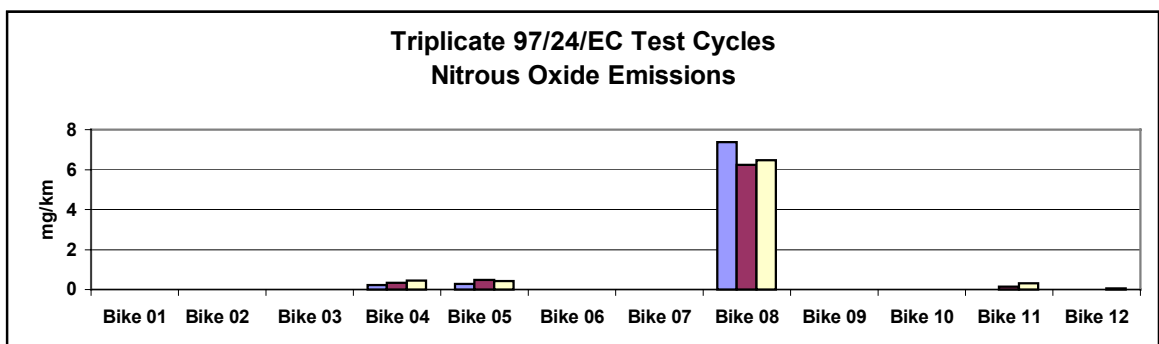
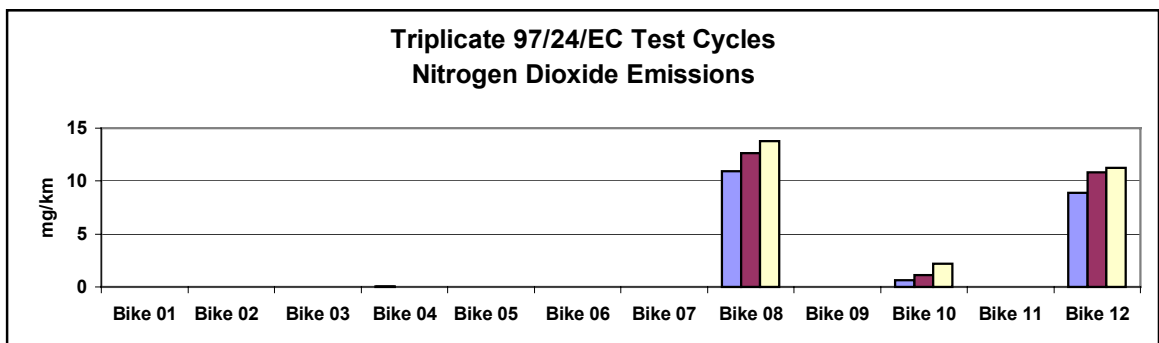
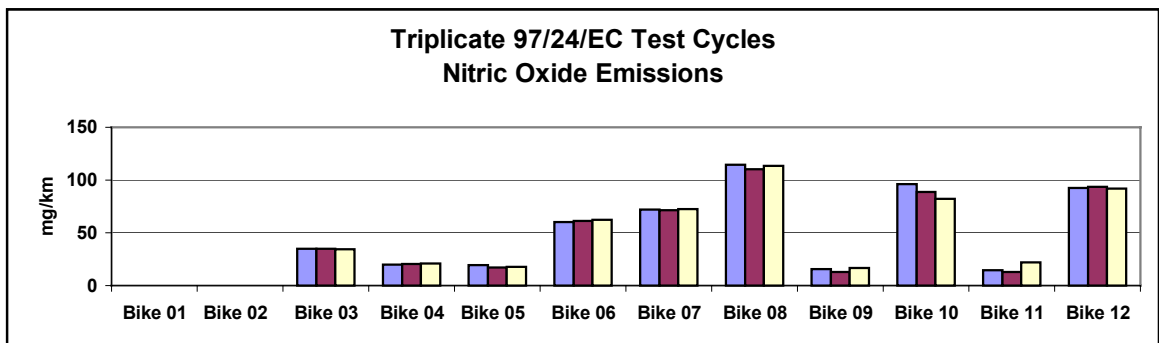
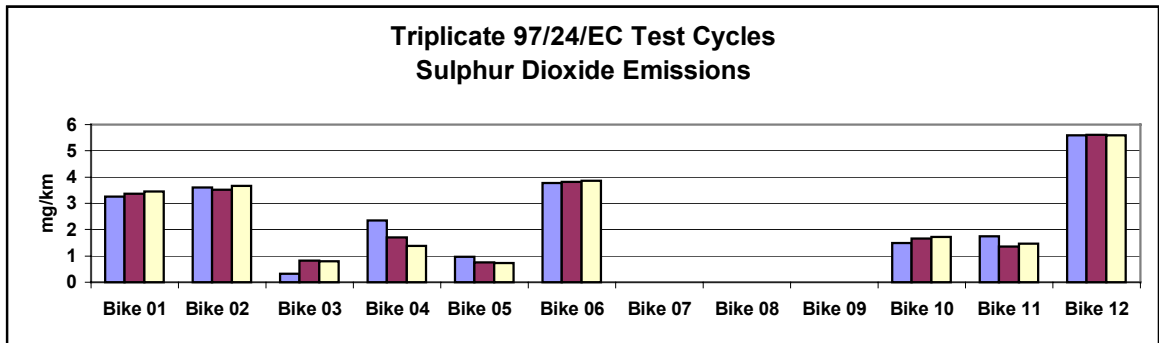

Figure 6 : Unregulated Emissions 97/24/EC Cycle





NO_x emissions from all bikes are clearly dominated by nitric oxide (>85%) with most bikes showing little or no NO₂ (nitrogen dioxide) or N₂O (nitrous oxide) emissions. The major exception was bike 8, a 2T DI equipped with an oxidation catalyst, which showed NO₂ (nitrogen dioxide) emissions of ~12mg/km (against ~110mg/km of NO) and N₂O (nitrous oxide) emissions of ~6.5mg/km. Formation of NO₂ (nitrogen dioxide) across an oxidation catalyst is not unexpected. Similarly, N₂O (nitrous oxide) production is known to be one of the products of NO reduction over Pt based catalysts. The other exceptions were air cooled bikes; 10 and 12 which produced ~1 mg/km and ~11mg/km of nitrogen dioxide respectively.

Bike 12 also produced the highest SO₂ (sulphur dioxide) emissions, though it should be noted that due to instrument unavailability, no measurements of this component were made from Bikes 6, 7 or 8. It is probable, since the emissions of other oxidised species (NO (nitric oxide) and NO₂ (nitrogen dioxide)) were similar between bikes 8 and 12, that Bike 8 would have produced similar SO₂ (sulphur dioxide) levels to Bike 12.

Methane emissions (CH₄) ranged from <10mg/km with bike 8 to >130mg/km from bikes 5 and 6. In general, higher levels were observed from bikes running richer strategies and equipped with three-way cats.

2.2 Particle Number Emissions

Highest levels of particle number emissions across the 97/24 cycle were observed from Bikes 8 and 11, both two-strokes. Particle emissions were observed to track the drive cycle closely with both the DI and carburetted types; increasing with accelerations, decreasing slightly but stabilising over cruises, and then dropping away considerably with accelerations (Figure 7a). High levels were also observed from Bike 2, which showed significant enrichments on over-runs. (Figure 7c).

Lowest levels were observed from the TWC equipped motorcycles (4 and 9) which operated near stoichiometry during this cycle. These motorcycles produced significant particle numbers on accelerations only. Low levels were also observed from those four-stroke motorcycles equipped with only a carburettor (1 and 6) that ran relatively rich across the cycle. On these bikes, levels of particles emitted in response to accelerations and gear changes were low with highest levels emitted Figure 7b).

Total particle number emissions spanned the range 8×10^{11} to 1.3×10^{13} /km (Figure 7). This range is similar to that which has been observed for MPI and DI gasoline vehicle types.

Figure 7 (a,b,c): Total Particle Number - Low and High Emitting Motor Cycles

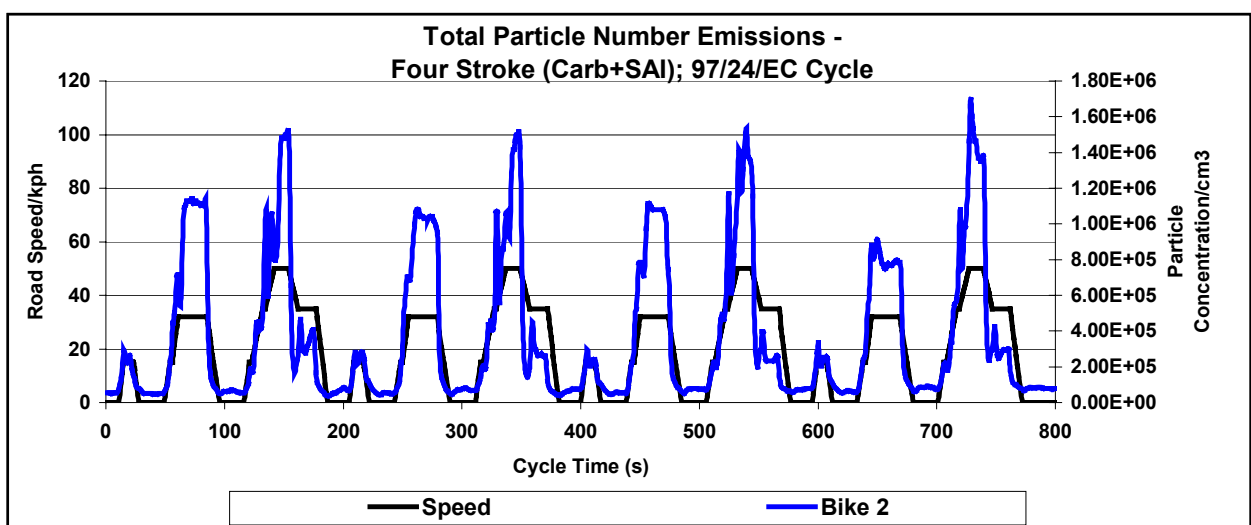
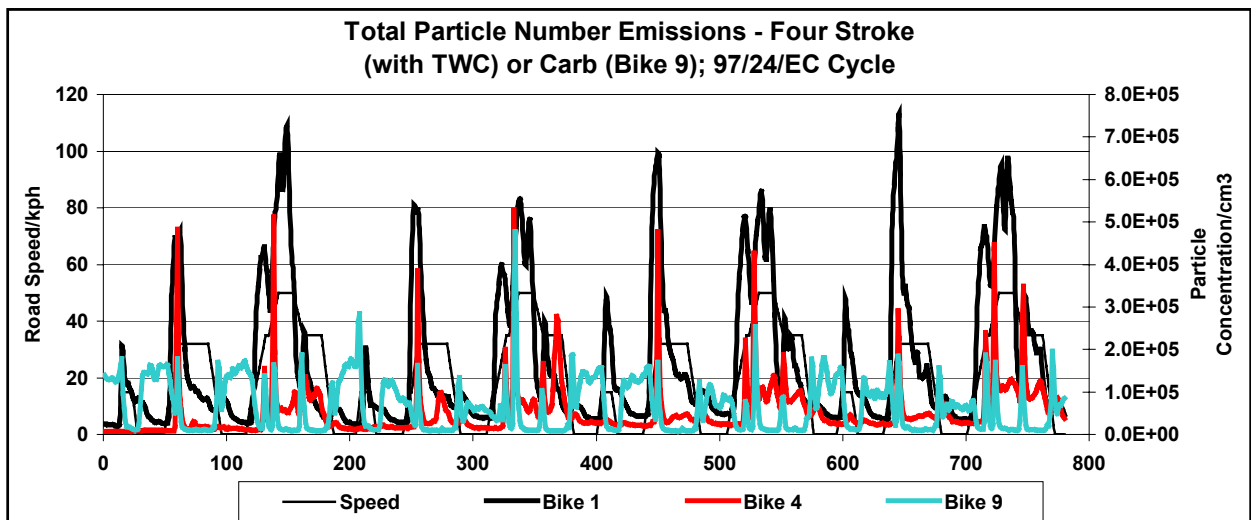
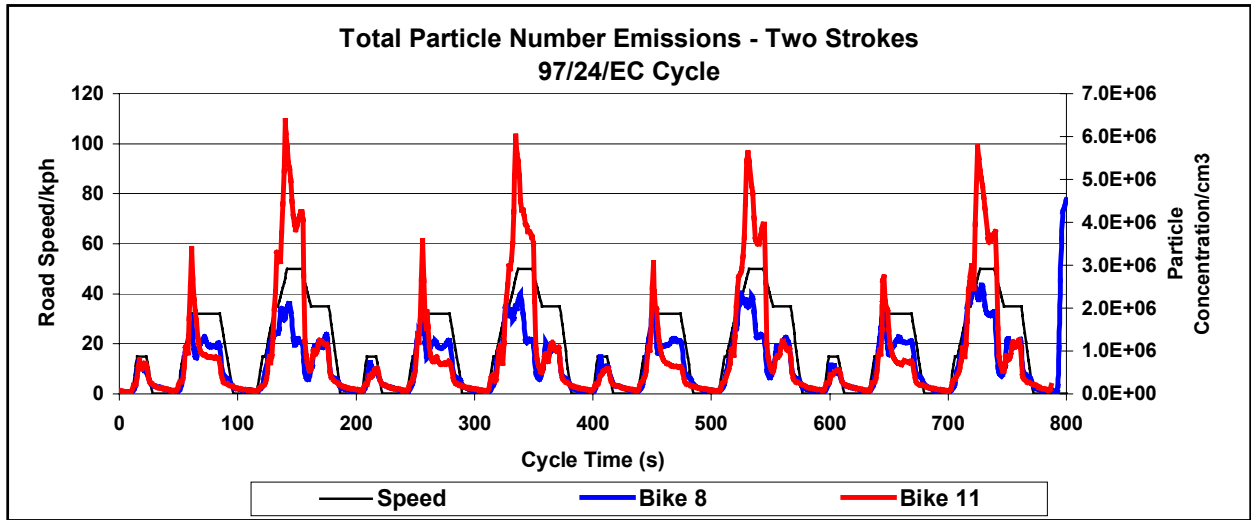
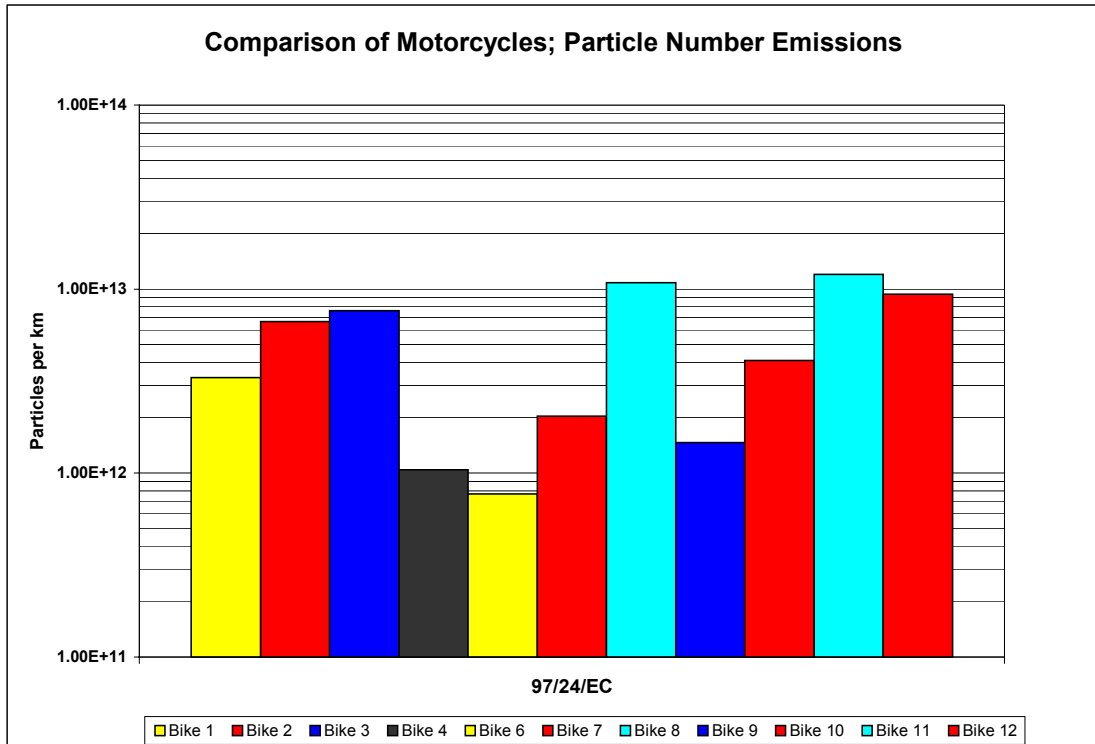

Figure 8 : Total Particle Number Emissions



2.3 Overview of Particle Number Production

Particle number emissions from the 11 motorcycles tested appear to be strongly related to motorcycle operating temperature. This may be related to combustion technology - as with the two-stroke DI, the presence or absence of aftertreatment, but generally appears related to calibration. Generally rich calibration maintains low combustion and exhaust temperatures, while lean combustion elevates these temperatures. Cycle demands and the ease with which an individual motorcycle drives the cycle also relate strongly to temperature and particle number emissions. In this respect, particle numbers may show synergy with NOx emissions.

Production of particles from some motorcycles appears to follow the drive trace quite closely. These appear to be those motorcycles which tend to run rich of lambda 1 but also include the DI 2-stroke motorcycle which always runs lean. Other motorcycles appear to produce particles in response to accelerations; these tend to be equipped with three-way catalysts.

While neither type shows the increases in particle numbers associated with decelerations that are commonly observed with petrol fuelled vehicles, overall particle number emissions (on a per km basis) from the 97/24/EC cycle are of the same order observed from MPI and DI petrol fuelled vehicles (Figure 8).

2.4 General Particulate Analyses : Motorcycle to Motorcycle Comparisons

The techniques employed for the general chemical analyses are described in Appendix 1. These analyses are employed to determine bike to bike differences in the chemistry of materials retained on a standard filter paper. Component specific data are shown as percentage contributions to the total measured mass and as absolute mass (mg/km) emissions. Figure 9 shows the key for the following six sets of figures which illustrate these comparisons.

Figure 9 : Key to Particulate Species

■ OIL DERIVED HC'S (mg/km)	■ CARBON (mg/km)	■ SOLUBLE SULPHATES (mg/km)
■ SULPHATE- BOUND WATER (mg/km)	■ NITRATE (mg/km)	■ REMAINDER (mg/km)

Oil derived hydrocarbon levels are determined by a gas-chromatography method, and not by thermogravimetry. This technique fundamentally excludes any hydrocarbons of fuel volatility.

Figure 10 shows chemical analyses data from the 97/24/EC drive cycles. These data are shown in both mg/km and percentage contribution terms.

With all motorcycles, particulate composition from the 97/24/EC cycle was dominated by oil hydrocarbons. With one exception, BK02 at 47%, these contributed at least 65% of the total mass. In the case of the two-strokes; BK11 (carb) and BK08 (DI) oil fraction was greater than 97% and the other 3% comprised trace carbon plus sulphate and nitrate.

The remainder contribution from four of the bikes was considerably higher than from any others; ranging from 16 to 43%. These motorcycles (BK02, BK07, BK10, BK12) were all carburetted and equipped with SAI and none were equipped with catalysts. Mass emissions from these bikes were however, low (<10mg/km). Visual inspection of these filters revealed no carbon and suggests that the remainder fraction is probably comprised of unburned fuel retained in the filter matrix.

The two carburetted four-strokes (BK01, BK06; no cat or SAI) produced no remainder fraction.

Sulphate levels were always less than 10% of total mass irrespective of motorcycle type, and nitrate levels never greater than 6%. Levels of these anions were lowest with the two-strokes.

Figure 10 : Particulate Chemistry

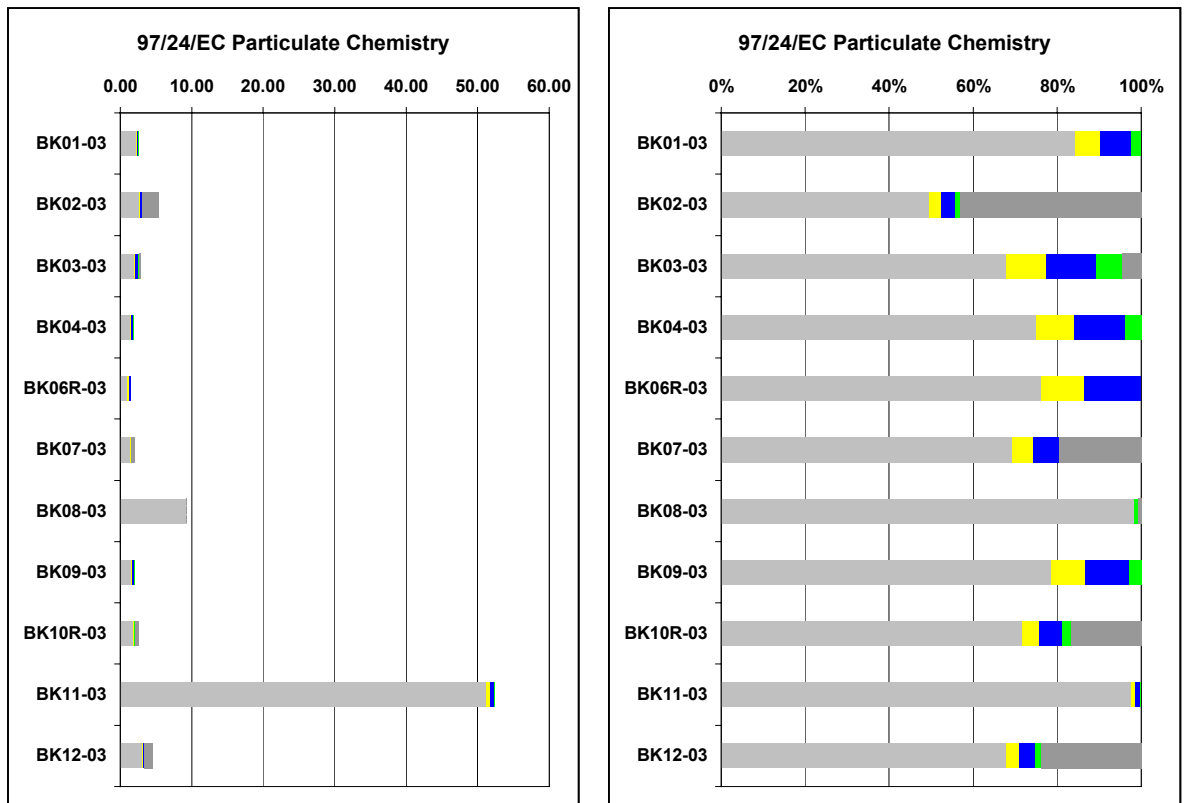

2.5 Particle Mass Emissions : Size Distributions and Total

Comparisons of particle mass emissions from the 97/24/EC cycles are described below:

Since mass emissions were generally very low, particle size distributions from the 97/24 cycle were mostly indeterminate (Figure 11). However, the two-stroke motorcycles were notable exceptions – BK11 showing levels several times those from any other bike and a mode at the 320 to 560nm stage, BK8 (the DI) showed lower levels and a mode at the 180nm to 320nm stage. It is worthy of note that while these motorcycles were tested on semi-synthetic lubricants, a move to fully synthetic lubricants has the potential to reduce 2-stroke particulate matter emissions.

The bike 11 distribution shows diesel character and suggests a size distribution comprised of carbonaceous materials, while bike 8 suggests a predominantly volatile distribution consistent with high temperature desorption.

Total mass emissions (Figure 12), calculated as the sum of all the MOUDI stages, were highest from Bike 11 at ~0.040g/km, but were in all cases lower than the Euro III Diesel emissions level of 0.05g/km. With the exception of bike 11, all other bikes' emissions were at least 50% lower than the Euro IV standard for diesel vehicles (0.025g/km).

Figure 11 : Comparison of Motorcycles - 97/24/EC Cycle

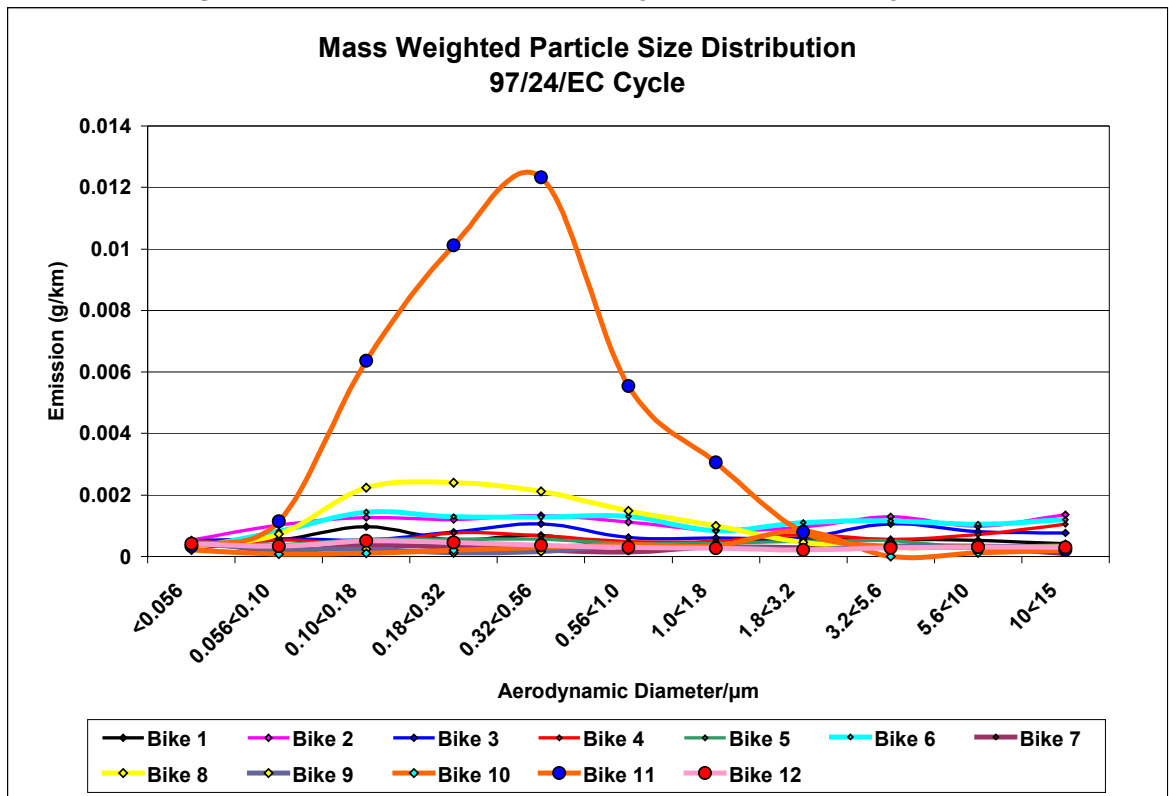
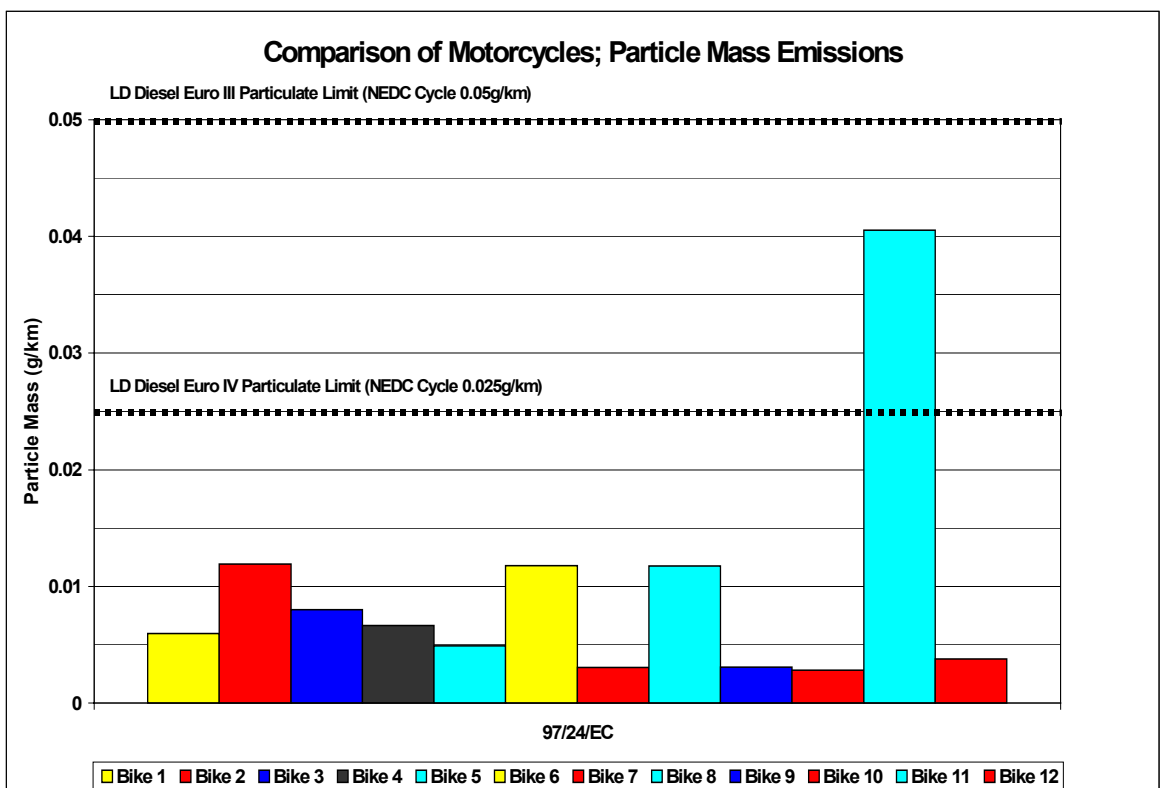

Figure 12 : Integrated Particle Mass - MOUDI



3 MOTORCYCLE EMISSIONS : COMPARISON WITH OTHER SECTORS

The comparison of the motorcycle emissions with those from other sectors is extremely difficult to estimate because of the large variety of motorcycle emissions and the lack of data concerning the composition of traffic. A literature research was done in the European community report database and in the Ricardo Powerlink database. Three documents are presented below. The first one is an air quality measurement performed in Italy in 1997. The second is the estimated contribution of each type of vehicle performed before 2000. The third is Ricardo comparison of automotive and motorcycle emissions based on Ricardo experience.

3.1 Air Quality Measurements in Milan

The Viale Murillo in Milan is a broad arterial road on the outer Milan ring road with approximately 500,000 vehicles per day. A short measuring campaign in November-December 1997 was conducted in this street. The traffic composition associated with this period is presented in Table 4 and the CO emissions Figure 13 and Figure 14. The motorcycle contribution represents less than 4% of the traffic. It is noticeable that on Sunday the 16th of November the emissions of CO were lower than the other days, but it is not possible to attribute this reduction to any particular vehicle as both the commercial vehicle and motorcycle traffic were significantly reduced.

Table 4 : Average traffic composition in Viale Murillo

Vehicle Type	% of traffic	
	Weekdays/Saturdays	Sundays
Passenger cars	87.8 %	97.2 %
Light duty commercial vehicles (< 3.5 t)	6.3 %	1.5 %
Heavy duty commercial vehicles (> 3.5 t)	1.4 %	0.1 %
Buses	0.6 %	0.4 %
Motorcycles	3.9 %	0.8 %

Figure 13 : Average CO emissions in Viale Murillo in November 1997

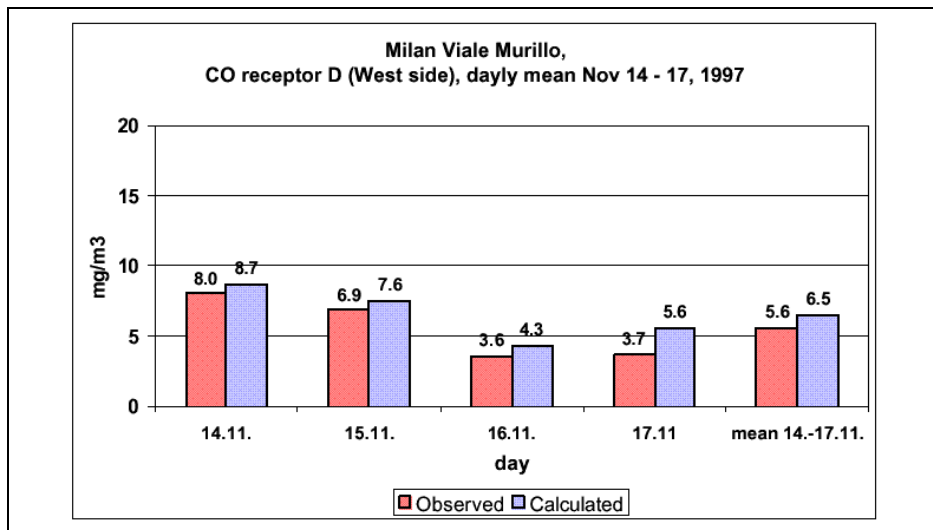
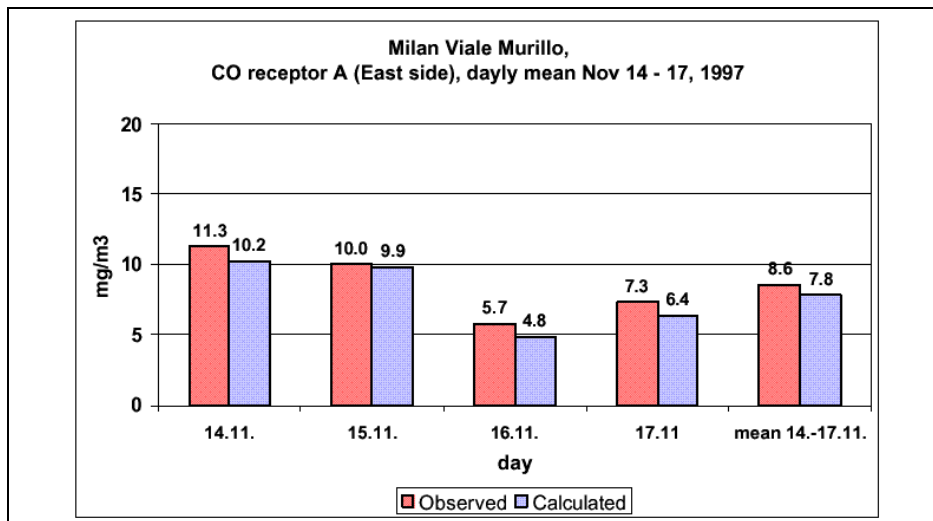

Figure 14 : Average CO emissions in Viale Murillo in November 1997



3.2 Vehicle Type Emissions Contribution Estimation

In a recent report the European Council of Applied Sciences and engineering [1] have proposed an estimation of the contribution of each type of vehicle to NO_x and particle emissions in UK (Figure 15 and Figure 16). The authors highlight the fact that the air quality impact of traffic congestion in urban centres is difficult to predict because it depends on the complex combination of vehicle parc profile, vehicle number, trip type and urban geography.

As with the Italian study, this prediction shows a small contribution from the motorcycle to the total emissions.

Figure 15 : Predicted Total transportation NOx emissions for UK

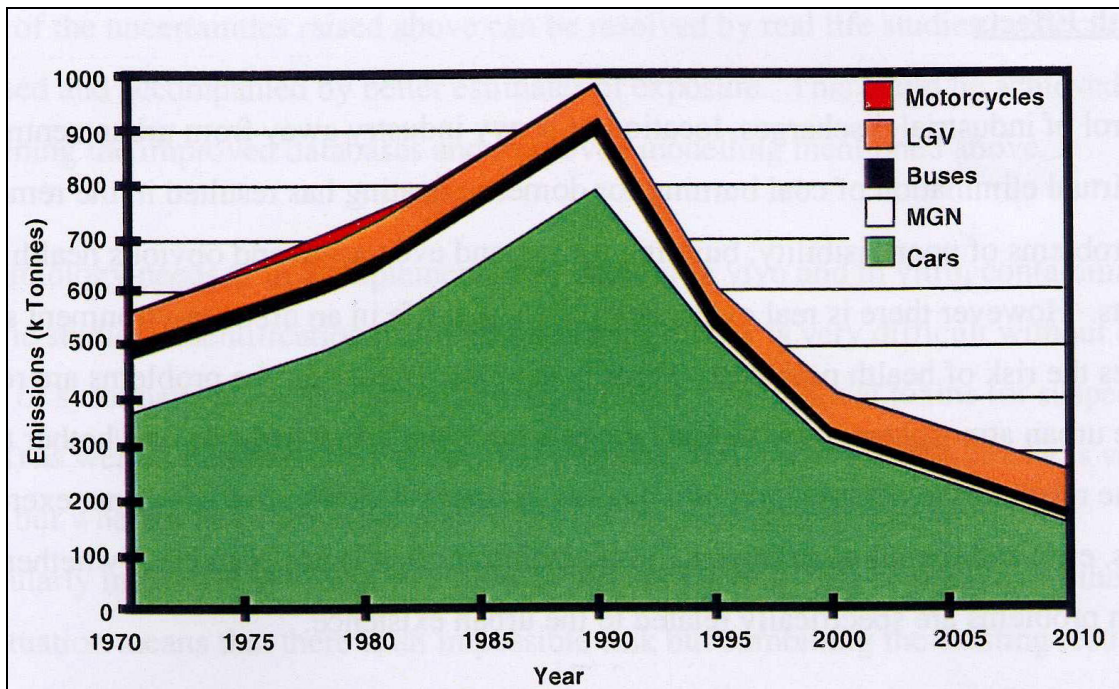
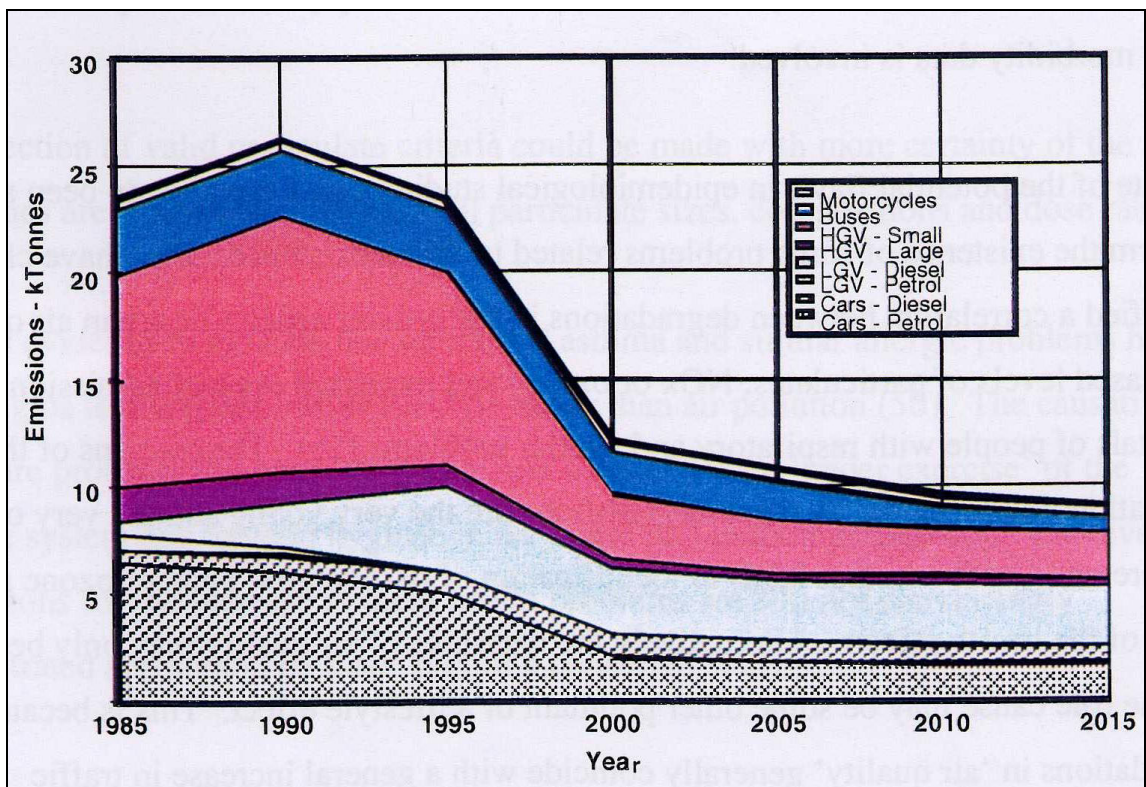

Figure 16 : Predicted Total transportation Particulate emissions for UK



3.3 Ricardo Emissions Comparison

Figure 17 and Figure 18 represent an average comparison of regulated and some unregulated pollutants over the European cycle. These averages have been calculated based upon 10 motorcycles and 9 automotive sources. The error bars represent the variations between vehicles. The vehicles are not wholly representative of the market but do cover the range of technologies currently available (diesel/gasoline, 4-strokes/2-strokes). In this respect, these figures should not be considered as presenting a comparison between fleet motorcycle emissions and fleet automotive emissions.

Table 5, Table 6 and Table 7 illustrate regulated emissions limits for passenger cars, motorcycles and three/four wheel motorcycles respectively.

Table 5 : Regulated Emissions Limits (Passenger Cars)

	Engine Type	HC + NOx (g/km)	CO (g/km)	HC (g/km)	NOx (g/km)	PM (g/km)
	Gasoline	0.5	2.2			
Euro II	IDI Diesel	0.7	1			0.08
	DI Diesel	0.9	1			0.1
Euro III	Gasoline	-	2.3	0.2		
2000	Diesel	0.56	0.64	-		0.05
Euro IV	Gasoline		1	0.1	0.08	
2005	Diesel	0.3	0.5		0.25	0.025

Table 6 : Standards for Two-wheeled Motorcycles

Introduction Date	Class (cc)	CO (g/km)	HC (g/km)	NOx (g/km)	PM (g/km)
Current	Two-Stroke	8.0	4.0	0.1	
	Four-Stroke	13.0	3.0	0.3	
2003	<150cc	5.5	1.2	0.3	
		2.0*	0.8*	0.15*	
	>150cc	5.5	1.0	0.3	
		2.0*	0.3*	0.15*	
2006	≤150	2.0	0.8	0.2	
	>150	2.0	0.3	0.1	

* Voluntary Limits for Fiscal Incentive Purposes

Note – Test Cycles: The current 97/24/EC test cycle (which is identical to ECE40) will be modified in 2003 deleting 40 seconds from the initial warm-up phase.

In 2006 a new mandatory emissions test cycle will be introduced based upon that described in the car directive 98/69/EC. Motorcycles below 150cc will follow an urban version of this cycle whereas motorcycles above 150cc will follow an additional part, which utilises vehicle speeds up to 120 km/h. In a break from tradition, from 2006, European legislators will also allow manufacturers to optionally utilise a motorcycle specific test cycle which is still under development at this time.

Table 7 : Standards for Tricycles and Quadricycles

Introduction Date	Class (cc)	CO (g/km)	HC (g/km)	NOx (g/km)	PM (g/km)
2003	Limit values for tricycles and quadricycles for type approval and conformity of production (positive ignition)				
	All	7.0	1.5	0.4	
	Limit values for tricycles and quadricycles for type approval and conformity of production (compression ignition)				
	All	2.0	1.0	0.65	0.10
	Limit values for motorcycles (two-wheel) for type approval and conformity of production				
2006	≤150	5.0	1.2	0.3	
	>150	2.9	0.25	0.2	
	Limit values for tricycles and quadricycles for type approval and conformity of production (compression ignition)				
	≤150	1.4	0.7	0.45	
	>150	0.8	0.15	0.65	

CO and Hydrocarbons emissions (Figure 17) are more important for motorcycles than they are for light duty vehicles. However it should be noted that for these, the highest motorcycle emissions can be for 4-stroke engines. The lowest emissions are similar to the passenger car levels and are from 2-stroke engines or from 4-stroke engines equipped with an SAI and a catalyst.

NOx emissions are in the same range from passenger car and motorcycle sources, although the average automotive emissions are slightly higher.

The narrow band of passenger car emissions is a consequence of the strict emissions legislation. In the case of motorcycle, the current legislation is less stringent and variations can be due to engine size, calibration and running condition; lean, stoichiometric, rich. However, as can be seen from the tables above, motorcycle legislation is also becoming more strict and as a result, it can be anticipated that the spread of emissions will become more narrow.

Figure 17 : Regulated Emission Comparison

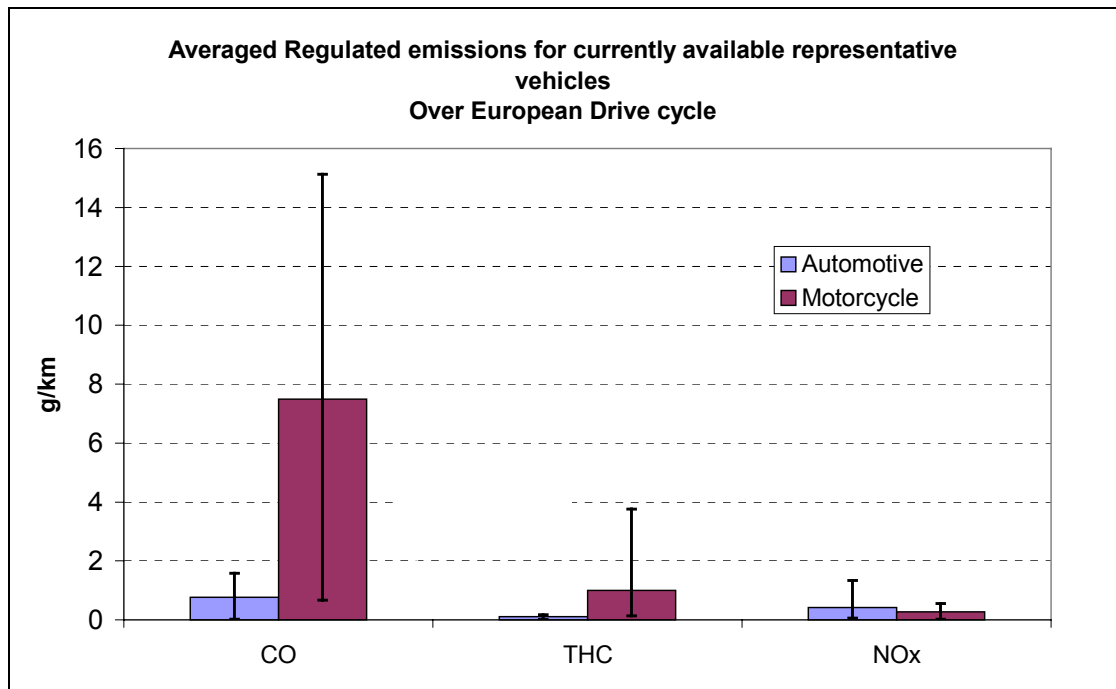

Emissions comparisons between motorcycles and cars are difficult to make due to the differences in test cycle demands, and the results inconsistent. For example, N₂O (nitrous oxide) emissions are higher from passenger cars than from motorcycle sources, with the opposite true for methane. Figure 18 below compares typical mg/km emissions from vehicles for various unregulated species with the range of emissions observed from the 2-stroke and 4-stroke motorcycles tested within this programme.

Figure 18 : Unregulated Emission Comparison

	Vehicle Diesel	Vehicle MPI Gasoline	Vehicle HD Diesel	Motorcycle 4T Max	Motorcycle 4T Min	Motorcycle 2T Max	Motorcycle 2T Min
Nitric Oxide(NO)	400	140	2850	100	15	120	15
Nitrogen Dioxide (NO ₂)	200	1	450	9	0.05	11	11
Nitrous Oxide (N ₂ O)	4	15	n/a	0.3	0.01	7.5	0.01
Ammonia (NH ₃)	5	10	10	40	0.01	2	0.6
Methane (CH ₄)	2	20	8	150	3	50	4
1,3-butadiene (C ₄ H ₆)	3	3	5	15	0.01	20	2
Formaldehyde (CH ₂ O)	6	1	20	50	4	60	20
Sulphur Dioxide (SO ₂)	0	9	n/a	6	0.01	2	2
Acetaldehyde (C ₂ H ₄ O)	3	0	13	20	0.01	25	20
Benzene (C ₆ H ₆)	1	4	2	90	6	110	6
Toluene (C ₇ H ₈)	n/a	5	n/a	1100	30	1200	60
C8-aromatics (C ₈ H ₁₀) (Xylenes and Ethylbenzene)	n/a	6	1	1250	30	1100	70

The following section briefly describes the approach to the reduction of emissions of gaseous emissions and particle species.

4 EMISSIONS REDUCTION

A key challenge for the smaller motorcycles and scooters will be the achievement of emissions goals with minimum add on cost.

For bikes up to around 600cc, the application of exhaust catalysts should generally be possible without a significant performance penalty. Secondary air injection will be required to give sufficient HC and CO reduction with an open loop EFI system. This enables the engine to run on the rich side for good driveability and control of NOx.

For the bigger machines, in particular the high specific output bikes, minimising any potential performance penalty imposed by relocation of the catalysts closer to the engine will be a key development challenge. These machines generally have all the elements of an advanced emission control package, but these systems need to be developed and further refined to meet the new legislation. For example, the existing reed valve secondary air systems will probably be developed to provide some form of modulation to control exhaust oxygen levels more closely than at present, to achieve stoichiometric conditions to allow 3 way catalyst operation. Current open loop will have to be replaced by a more sophisticated closed loop control, and control strategy system. In that respect, lambda sensors will be required to give reduced cold start emissions and improved transient fuelling control. Incorporation of OBD will also increase complexity, although some existing systems have OBD capability, having been derived from automotive systems. The fuelling system will require more detailed calibration to work over a much wider speed and load range,



as the new drive cycles will dictate a more controlled driveability/emissions trade off at much higher speeds and loads than at present.

In respect of the above, the following technologies are likely to be explored:

- Increased sophistication of ECU control strategies for cold start and transient fuelling optimisation. Increased use of closed loop fuelling control.
- Increased sophistication of current catalyst and secondary air injection systems including fast light off, detailed precious metal formulation optimisation, and possible SAI modulation to control exhaust AFR.
- Increased utilisation of 2 stroke direct injection systems for small capacity machines
- Possible development of 'new' systems such as EGR, and de-NOx catalysts, should future legislation dictate the use of such systems
- Possible incorporation of OBD and evaporative control systems

The catalysts themselves may need to be bigger and with improved formulations. In addition, they may need to be located closer to the engine to improve light off, or the system may need to incorporate starter/light off catalysts, and will be required to achieve up to 50,000 km durability.

Reduction of emissions by catalysis is extremely dependent on the type of motorbike (4 strokes or 2 strokes) and on the combustion system used (Rich, lean, stoichiometric). As a rule of thumb, a catalyst is able to reduce hydrocarbons and CO under a lean mixture and NO_x under a rich mixture. It should be noted that because of the exhaust temperature and the catalyst size (which is generally lower than in a automotive application) the catalyst performance is likely to be lower.

For two reasons methane and benzene are difficult to reduce; because they are stable molecules and because they are by-products of cracking of heavier hydrocarbons and aromatics. This cracking can occur at high temperatures and with rich operation. In some cases post catalyst emissions may be higher than engine out.

N₂O (nitrous oxide), NH₃ are NO_x reduction by-products. Some work is ongoing within the catalyst industry to develop formulations which have low selectivity towards N₂O formation. However, the durability of some novel formulations still needs to be demonstrated.

5 HEALTH EFFECTS OF POLLUTANTS

A chemical compound can be designated as "pollutant" for many reasons

- Direct health effect
- Environmental effect
- Other inconvenient effects (odour, colour,...)

Benzene

Benzene is a known human carcinogen and causes various types of leukaemia, lymphoma, and blood diseases. The use of benzene as a solvent has been banned in the United States for more than twenty 20 years.

While the Occupational Safety and Health Administration's (OSHA) permissible exposure limit for benzene is 1 ppm, it can still cause harm at this level. Thus the American Conference of Governmental Industrial Hygienists (ACGIH) has recommended a threshold limit value of 0.5 ppm, and the National Institute for Occupational Safety and Health (NIOSH) has set a Recommended Exposure Limit of 0.1 ppm.

1,3-Butadiene

A colourless, non corrosive gas with a mild aromatic or gasoline-like odour. It is known to be a human carcinogen based on evidence of carcinogenicity from studies on humans. These include epidemiological and mechanistic information, which indicate a causal relationship between occupational exposure to 1,3-butadiene and excess mortality from lymphatic and/or hematopoietic cancers.

Formaldehyde

Formaldehyde, the smallest possible carbonyl compound, is classified as a human carcinogen and has been linked to nasal and lung cancer, with possible links to brain cancer and leukaemia. Short-term exposure to it can be fatal. However, the odour threshold is low enough that irritation of the eyes and mucous membranes will occur before these levels are achieved. Long-term exposure to low levels of formaldehyde may cause respiratory difficulties, eczema, and sensitisation.

Acetaldehyde

Acetaldehyde occurs as a volatile, flammable, colourless liquid. At high concentrations this carbonyl compound has a pungent, suffocating odour, while at dilute concentrations it has a pleasant, fruity odour. It is reasonably anticipated to be a human carcinogen based upon sufficient evidence of carcinogenicity in animal experiments.

The following table examines the cancer potency ratios (which measures the weighted toxicity) of four pollutants associated with motor fuels and specifically identified by reformulated gasoline (RFG) requirements. For purposes of comparison, the pollutants are compared to benzene, which is assigned a potency ratio of 1.

Pollutant Potency Ratio	
1,3 – butadiene	3.58
Benzene	1
Acetaldehyde	0.07
Formaldehyde	0.004

Table 8 : Pollutant cancer Potency Ratio

NO_x - NO (nitric oxide) and NO₂ (nitrogen dioxide)

NO_x emissions produce a wide variety of adverse health and welfare effects in addition to contributing to ozone formation. Nitrogen dioxide can irritate the lungs and lower resistance to respiratory infection (such as influenza). NO_x emissions are an important precursor to acid rain and may affect both terrestrial and aquatic ecosystems. Atmospheric deposition of nitrogen leads to excess nutrient enrichment problems (“eutrophication”). Eutrophication can produce multiple adverse effects on water quality and the aquatic environment, including increased nuisance and toxic algal blooms, excessive phytoplankton growth, low or no dissolved oxygen in bottom waters, and reduced sunlight causing losses in submerged aquatic vegetation critical for healthy estuarine ecosystems. Nitrogen dioxide and airborne nitrate also contribute to pollutant haze.

N₂O (nitrous oxide)

Nitrous oxide (N₂O (nitrous oxide)) is an important long-lived greenhouse gas that, in nature, is emitted predominantly by biological sources in soil and water. It is also the primary source in the stratosphere of the oxides of nitrogen, which play a critical role in controlling the abundance and distribution of stratospheric ozone. N₂O (nitrous oxide) is primarily removed from the atmosphere in the stratosphere by photolysis (breakdown by sunlight). A secondary removal process (which accounts for about 10% of removal) is through a reaction with excited oxygen atoms. There is some evidence that soils may represent a small sink for N₂O (nitrous oxide), but, to date, there is not enough data to evaluate this [2].

Apart from N₂O (nitrous oxide), 3 other greenhouse gases are listed in the Kyoto protocol (CO₂, CH₄, CFCs). Their greenhouse effect potentials are presented in Table 9 : Global Warning Potentials (GWPS). In this table, the relative contributions to Global warming per unit mass of component are normalised to Carbon Dioxide. Based on the quantity of emitted pollutants and their Global warming potentials it is possible to evaluate the global greenhouse contributions of the 4 pollutants (Figure 19).

This figure demonstrates that while per unit mass methane is 24,000 times less potent a global warming agent than Chlorofluorocarbons (CFCs), the high volumes of methane released still account for more than twice the effect of total CFCs.

Methane

As a contributor to climate change, methane is second only to Chlorofluorocarbons (CFCs). Over the last two centuries, methane concentrations in the atmosphere have more than doubled, largely due to human-related activities. Reductions of about 10 percent in emissions from these anthropogenic sources would halt the annual rise in methane concentrations, effectively contributing to mitigation of climate change [3].

Table 9 : Global Warning Potentials (GWPS)

CO ₂	Methane (CH ₄)	N ₂ O (nitrous oxide)	CFCs
1	21	310	23900

Figure 19 : Gas greenhouse effect, based on quantity and radiation adsorption potential []

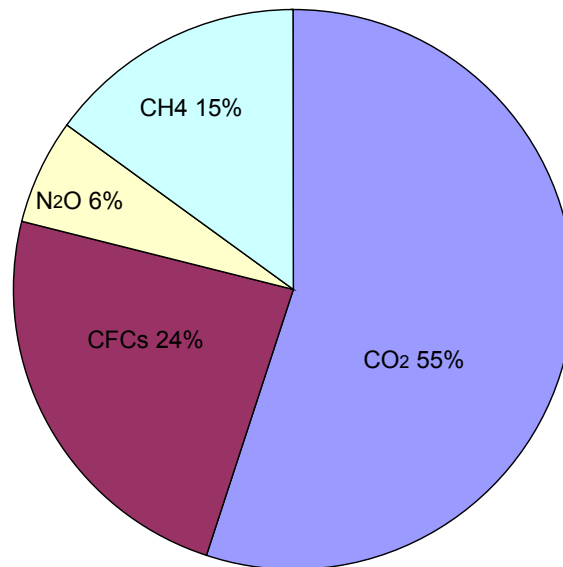

Toluene [4]

Once emitted into the air, toluene combines with oxygen to form benzaldehyde and cresols (hydroxybenzenes). In addition, it contributes to the tropospheric formation of ozone. It is considered to be non-genotoxic and non carcinogenic.

Sulphur Dioxide (SO₂)

At ambient temperature and pressure, sulphur dioxide is a colourless gas. In the late nineteenth century and first half of the present century, sulphur dioxide in combination with sooty particles was responsible for smog episodes in industrial cities.

After being released in the atmosphere, sulphur dioxide can be further oxidised to sulphate and sulphuric acid forming an aerosol often associated with other pollutants in tiny droplets or solid particles extending over a wide range of sizes. SO₂ and its oxidation products, are removed from the atmosphere by wet and dry deposition. In spite of these processes of transformation and removal, sulphur dioxide can be transported over large distances, causing transboundary pollution. Nowadays, it is also recognised that sulphate (SO₄²⁻) aerosols play an important cooling role in the radiative climate of the earth through the phenomena of sunlight scattering in cloud free air and as cloud condensation nuclei.

Hydrogen sulphide (H₂S) [5]

H₂S has a recognisable odour ("rotten eggs") detectable at levels as low as 0.15 ppm but becoming intolerable at 27ppm. At a concentration of 100 ppm, eye irritation and loss of sense of smell occur after 2 to 15 minutes. At concentrations approaching 700ppm, H₂S causes rapid unconsciousness and prolonged exposure, death.

5.1 Pollutant Exposure Limits and Exhaust Concentrations

The Occupational Safety and Health Administration (OSHA) has recommended limits for daily workplace exposures for many of the compounds described in Section 5. Table 10 shows how these exposure limits compare with tailpipe emissions levels from the various motorcycles tested.

Table 10 : Pollutant Emissions and Exposure Limits

Summary	Benzene	1,3-butadiene	C8 aromatics	C9 aromatics	Hydrogen Sulphide	Sulphur Dioxide	Toluene	Nitric oxide	Nitrogen dioxide	Nitrous oxide	Methane	Formaldehyde	Acetaldehyde	Ammonia
OSHA 8h day, 40h week workplace exposure limit (ppm)	1ppm	100ppm	100ppm	Not defined	20ppm	2ppm	200ppm	25ppm	1ppm	25ppm (NIOSH)	Not defined	1.5mg/m3	100ppm	50ppm
Bike 1	34.4	12.7	91.7	72.7	0.2	3.2	110.2	No data	No data	No data	No data	No data	No data	No data
Bike 2	80.9	7.6	693.1	524.3	0.3	3.8	728.4	No data	No data	No data	No data	No data	No data	No data
Bike 3	21.1	4.7	36.7	31.4	0.1	0.3	45.1	36.0	0.0	0.0	121.1	26.9	8.9	33.9
Bike 4	7.5	0.4	10.2	8.2	0.0	1.0	12.4	25.1	0.0	0.3	79.7	4.7	0.5	54.4
Bike 5	31.7	6.2	40.6	29.1	0.1	0.5	53.5	25.0	0.0	0.4	358.9	10.6	2.4	79.9
Bike 6	46.1	13.3	91.4	69.3	0.2	2.6	133.7	89.2	0.0	0.0	344.4	71.2	11.8	4.3
Bike 7	19.0	2.8	103.8	56.1	0.1	No data	88.2	129.4	0.0	0.0	109.1	45.3	0.0	5.1
Bike 8	9.8	3.9	82.3	75.5	0.3	No data	80.3	455.1	32.8	18.4	28.0	76.8	71.7	4.0
Bike 9	2.8	0.4	7.8	6.3	0.0	No data	7.4	14.3	0.0	0.0	117.7	4.5	0.4	41.3
Bike 10	31.9	7.4	94.9	66.4	0.2	1.6	95.5	192.0	1.9	0.0	197.8	58.2	24.8	5.0
Bike 11	89.7	23.2	682.0	492.6	0.5	2.2	820.0	50.0	0.0	0.3	236.7	207.1	57.0	7.5
Bike 12	12.7	2.6	24.6	18.3	0.2	3.4	39.1	120.2	8.7	0.0	78.3	39.3	13.8	3.7

It should be noted that in the real world, exhaust concentrations of these pollutants will be reduced by a factor of 1000 with ~1s of exiting the tailpipe.

6 POSSIBLE LEGISLATION OF UNREGULATED POLLUTANTS

Apart from formaldehyde, methane and NOx none of the unregulated pollutants studied here are currently subject to legislation for vehicle applications.

As part of NMOG (non-methane organic gases) Formaldehyde is legislated in US for passenger car and methane is regulated for gas engines.

Many emission reduction agreements have been set in Europe. It is generally the starting point for any legislation.

The European Union Environment Council has agreed to set upper limits for annual emissions for each member state of SO₂, NO_x, VOCs and NH₃. (Table 11) [6].

The aim of the directive to be met by the Community as a whole by 2010, is to improve protection of the environment and human health by limiting emissions of these four pollutants responsible for acidification, eutrophication, and ground level ozone pollution.

Table 11 : National Emissions Ceilings to be attained by 2010

Country	SO ₂ Kilotonnes	NO _x Kilotonnes	VOC Kilotonnes	NH ₃ Kilotonnes
Austria	39	103	159	66
Belgium	99	176	139	74
Denmark	55	127	85	69
Finland	110	170	130	31
France	375	810	1050	780
Germany	520	1051	995	550
Greece	523	344	261	73
Ireland	42	65	55	116
Italy	475	990	1159	419
Luxembourg	4	11	9	7
Netherlands	50	260	185	128
Portugal	160	250	180	90
Spain	746	847	662	353
Sweden	67	148	241	57
United Kingdom	585	1167	1200	297
EC 15	3850	6519	6510	3110

At a conference held December 1 - 11 1997, in Kyoto, Japan, the Parties to the UN Framework Convention on Climate Change agreed to a Protocol to reduce greenhouse gas emissions by harnessing the forces of the global marketplace. The protocol is mainly concerning the production of energy and essentially electricity but the issue could be transferred to automotive emissions either. At the moment the automotive manufacture agreed to reduce their CO₂ emission to 140g/km in 2008 and to 120g/km in 2012. As N₂O (nitrous oxide) and Methane have higher Global warming potential, they may be the next target.

There is also the possibility of the control of benzo[a]pyrene, a polycyclic aromatic hydrocarbon. These compounds are known to be emitted by both SI and CI sources. The emissions of these compounds from motorcycles requires further investigation.

7 CONCLUSIONS

After careful analysis of the report, ACEM are able to draw the following conclusions:

- Further research will be needed in the future to explore the effect on unregulated emissions of changing test cycles and the technology shift brought about by lowering regulated emissions limits. Although predictive analysis derived from this report could be used, it would remain open to doubt until proven in laboratory conditions. The important consideration being that the motorcycles tested in this programme were all developed to comply with existing European regulation based on low-dynamic test cycles and relatively high regulated limits when compared to limits for other transport sectors. Once manufacturers begin to develop machines for much lower regulated limits that are tested on more dynamic test cycles, the sophisticated emissions control devices which will be used will certainly alter the unregulated emissions situation.

- Although particulate mass emissions from the two stroke motorcycles tested were much higher than from the four stroke machines, they remain lower than the Euro III limits set for compression ignition engines in passenger cars.
- With one exception, the particulate mass emissions from all motorcycles tested were at least 50% below the Euro IV limits set for compression ignition engines in passenger cars. Based on this, it is difficult to see any need for particulate mass legislation for motorcycles, either 2 or 4-stroke.
- In general, motorcycle particulate emissions are comparable with those of passenger cars with multi-point fuel injection or direct injection systems. It is worth noting that only diesel cars have a particulate mass limit as part of the type approval process.
- In recognition of the shift in particulate focus from mass to size and number, continued vigilance for further research opportunities and information sources is needed in this respect.
- The emissions reduction techniques described in chapter four are by no means exhaustive. Development testing within the motorcycle industry has really only just begun in respect of the 2006 legislation and a much wider spectrum of control techniques can be anticipated. However, a simple technology shift from the passenger car sector is unlikely as the components used in motorcycles are smaller and the dynamic range of motorcycle engine is greater by a factor of 2-4 at least.
- Benzene and methane emissions may be decreased, but not significantly, by the techniques used in motorcycles in order to meet the 2006 legislation. As both are difficult to reduce anyway, based on the analysis made by Ricardo in chapter 4, it is difficult to see how any legislation can be applied to these pollutants in the future. An alternative may be to examine reductions through fuel formulation changes. However, the effect on production vehicles must be researched thoroughly first.
- Nitrous oxide would also be difficult to regulate (by legislation) as it is generated as a result of reducing regulated emissions by catalytic conversion. In preparing future legislation, regulators must consider the balance between reduction of one pollutant with the consequential and unavoidable increase in another.
- Although table 10 shows, in some cases, higher than recommended levels of certain pollutants from the tested motorcycles, the report correctly points out that the measurements are taken directly from exhaust emissions without taking account of the effect of atmospheric dilution.
- Due to the lack of information in respect of unregulated pollutants from other sectors of road transport, it is difficult to assess the contribution of motorcycles overall. However, what is clear from the report is that unregulated emissions from motorcycles should not be a concern currently. Taking account of the changes prescribed for regulated pollutants, it is unlikely that this situation will change radically in the foreseeable future.
- ACEM must continue to be vigilant at all times, for developments in the field of unregulated pollutants. Reduction technique research, fuel and oil formulations, research papers, technology changes and all other related aspects of the subject will need to be monitored by member manufacturers.

Appendix 1: Methods For Unregulated Emissions Analyses

Measurements of various gaseous and particle components of the motorcycles' exhaust aerosols were undertaken. These analyses employed a number of specialised instruments; condensation particle counter (CPC), Micro Orifice Uniform Deposit Impactor (MOUDI), Fourier Transform Infra-red Spectrometer (FTIR) and On-line Mass Spectrometer (OLMS). Off-line chemical analyses of particulate filters were also performed. Instrumentation and chemical analyses are briefly described in the following sections:

Condensation Particle Counter

Total particle concentration in the size range ~5nm to ~5µm is measured by CPC.

Within the CPC, particles are drawn by an internal pump at a constant 300 ml/min where they enter an alcohol saturation chamber. This chamber is held at 35°C and particles entering become saturated with 1-butanol. Once saturated, the particles flow into a condenser which is temperature controlled to 10°C, and under reduced pressure contains a supersaturated atmosphere. Butanol droplets condense onto the already alcohol soaked particles causing them to grow to spheres of about 12µm. This mechanism is independent of their initial diameter. These large, uniform particles are then detected and counted by an optical light scattering method.

Figure 20 : Condensation Particle Counter (CPC)

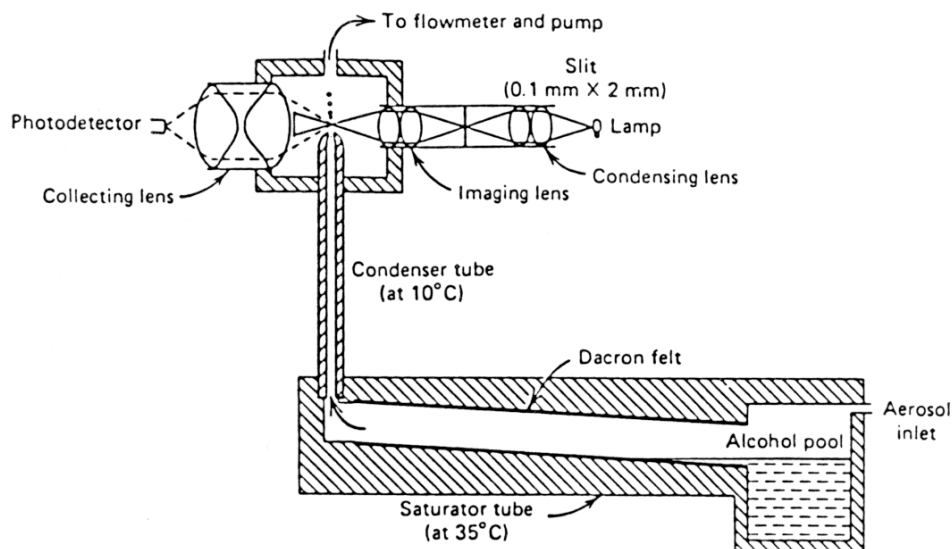

The CPC has two modes of operation; single count mode, where all particles are counted individually, and photometric mode, where bulk opacity is related to total particle number. The changeover between these modes occurs at 10,000 particles/cm³. In order to ensure that the measured particle concentration remains consistently in the linear mode, a secondary dilution system was employed. This comprised a dual ejector system, which increased CVS dilution by 150 times prior to measurement.

Micro Orifice Uniform Deposit Impactor (MOUDI)

Mass distribution levels were determined using a cascade impactor variant known as a MOUDI. This instrument separates exhaust aerosol into eleven size discriminated stages which represent mass fractions ranging from $> 10 \mu\text{m}$ to $< 50 \text{nm}$. The stages are arranged in a stack such that the largest particles are collected at the top.

In the MOUDI, particles are accelerated through nozzles above each collection plate and directed at a collection substrate. Particles of sufficient inertia overcome the streamlines, impact on the plate and are collected, while particles of lower inertia continue with the air stream. As the air stream progresses down through the stack, the acceleration of the particles through the nozzles increases, and particles with progressively lower inertia are collected. At the base of the impactor all the remaining particles are collected on a filter. Alternate stages of the impactor rotate, and nozzles are oriented to enable retention of material as concentric rings and minimise particle bounce.

Glass fibre/Teflon filters (PALLFLEX, CONN., USA) of 47mm (T60A20-47) and 37mm (TX40HI20-WW-37) diameter were used for the impaction stages and after-filter respectively.

Fourier Transform Infra-red Spectroscopy (FTIR)

Fourier transform infra red (FTIR) spectroscopy uses the absorption of energy in the infra-red region coupled with rapid deconvolution of the resulting spectra to identify and quantify key exhaust species.

Raw gas is pumped via a line heated at 185°C into the analyser cell. Here, the sample is scanned by the spectrometer once every second and the digitised spectrum transmitted to the computer. Individual hydrocarbons produce distinctive infra-red spectra. The FTIR software uses a mathematical process to “de-construct” the IR spectrum of the complex mixture of molecules into its contributory parts. The FTIR is a semi-quantitative tool with typical measurement deviations of less than 10%.

FTIR is well suited to the analysis of small hydrocarbons and combustion species as follows:

- Selected hydrocarbons:
 - aliphatic - methane, ethane, ethane, ethane, propane, propane, 1,3-butadiene
 - aldehydes - e.g. formaldehyde

- Inorganic gaseous emissions - e.g. nitric oxide, nitrogen dioxide, nitrous oxide.

On-line Mass Spectrometry (OLMS)

Whilst the FTIR provides detailed information on the small combustion product exhaust species, the use of a mass spectrometer (MS) provides additional on-line information on a range of important species, including aromatic species. Mass spectrometry uses the unique mass spectra of the exhaust species to resolve the complex exhaust mixture. The raw exhaust gas (from a probe position or trap-out) is pumped via a heated line to the mass spectrometer where the compounds are ionised. Fragmentation of the compounds occurs depending on their chemical structure. Some compounds, such as aromatics, fragment in a unique way, enabling identification. The compounds are detected as a function of their mass/charge ratio. Quantification accuracy is within 5-10% of the calibration standards.

On-line mass spectrometry enables quantification of compounds such as:

- selected hydrocarbons:
 - ⇒ aliphatics - eg. ethene, 1,3-butadiene, butene, C7 - C12 alkanes and alkenes
 - ⇒ aromatics - eg. benzene, toluene, xylenes, trimethylbenzenes
 - ⇒ aldehydes - eg. propionaldehyde, butraldehyde
- selected inorganics: ammonia, hydrogen sulphide, sulphur dioxide.

Off-line Chemical Analyses

The analyses of the volatile organic, anionic and PAH constituents of selected samples were undertaken according to the following procedures:

Analysis of Volatile Organic Fraction by Solid Injection Gas Chromatography

The fuel- and oil- hydrocarbons, classified as the volatile organic fraction (VOF), can represent an important part of the total particulate mass.

Particulate samples were collected onto GF/A Whatman filter papers. The total particulate mass on the filter was recorded and a sector of the filter paper directly injected onto a capillary gas chromatograph with flame ionisation detection. Calculation of the contribution of the fuel and oil to the total chromatogram was calculated by simultaneous equations. The solid injection technique and simultaneous equations method for calculation were both developed in-house at Ricardo.

Analysis of Sulphate, Nitrate and Phosphates by Ion Chromatography

Sulphate contributions to particulate mass can be significant, whilst nitrates and phosphates can account for small portions of particulate mass.

In each analysis, a sector of particulate-laden filter was extracted over a 24 hour period in an aqueous iso-propanol solution (10% v/v) and the extract subjected to ion chromatography.

Appendix 2

MOTORCYCLE EXHAUST EMISSIONS PROGRAMME – REGULATED EMISSIONS REPORT

1 INTRODUCTION

This report is submitted at the request of ACEM (reference fax to Ricardo from Federico Galliano dated 29 January 2002), and gives bike-to-bike comparisons for regulated emissions only on twelve motorcycles tested.

Unregulated emissions results and analysis will be included in an accompanying report.

2 OBJECTIVE

- To generate regulated and unregulated emissions data suitable for the calculation of emissions factors for a number of motorcycles (scooters to superbikes)

3 TECHNICAL APPROACH

The twelve motorcycles were chosen to give a representative range of models available in Europe, and were evaluated for regulated emissions, selected unregulated emissions, and particle parameters.

3.1 Motorcycle Testing

Each bike was tested over the 97/24/EC emissions test, the current type approval test. Triplicate tests were undertaken on each bike in order to understand repeatability of each bike and hence have confidence in the differences in emissions seen between bikes. The use of the type approval test would also enable comparison with other data, should this be required.

4. SCOPE OF WORK

4.1 Test Variables

4.1.1 Description of Motorcycles

The test machines were mainly of European specification and less than 12 months old. Of the 12 machines tested, 10 were 4-stroke and 2 were 2-stroke motorcycles, and each was supplied serviced prior to testing.

4.1.2 Motorcycle Preparation

On receipt, each machine was instrumented for engine-out coolant temperature and sump temperature, employing surface 'K' type thermocouples. The thermocouple to measure the former was positioned on the coolant pump body, and the latter attached to the engine oil sump. The exception to this was the air cooled motorcycles, where the coolant thermocouple was attached to the cylinder head on the external surface of a cooling fin.

4.1.3 Fuel and Lubricant Specification

Petrol from a single batch, conforming to the specifications contained in Table 1 to Annex IX of Directive 98/69/EC, was used as test fuel.
All motorcycles were tested with lubricants as received.

4.2 Test Cycle

The basic emissions test cycle used for the programme was that as outlined in the directive 97/24/EC (Chapter 5 Annex 2)

4.3 Test Protocol

3 x 97/24/EC emissions cycles were conducted on each bike. Typically, the 3 tests were conducted in one day with a forced cool down of half an hour between each test.

4.4 Test Schedule

The motorcycles were tested according to the schedule in Table 1 below:

Table 1 : Test Schedule

Test Day	Motorcycles Tested
1 (Oct 23)	1
2 (Oct 24)	2
3 (Oct 30)	3
4 (Oct 31)	4
5 (Nov 1)	5
6 (Nov 2)	6
7 (Nov 13)	7
8 (Nov 14)	8
9 (28 Nov)	9
10 (29 Nov)	10
11 (3 Dec)	11
12 (4 Dec)	12

4.5 Emissions Measurements

Regulated and unregulated emissions were measured according to Table 2 below:

Table 2 : Emissions Measurement – Species and Methods

Emission	Regulated/ Unregulated	Analytical Technique
HC	Regulated	Flame Ionization Detector (FID)
CO	Regulated	Non-Disperse Infra-Red (NDIR)
NO _x	Regulated	Chemiluminescence
CO ₂	Regulated	NDIR
PM	Unregulated	47mm GFA Filter Paper
NH ₃ , N ₂ O, H ₂ S	Unregulated	Fourier Transform Infra-Red (FTIR)
Benzene, 1,3-butadiene, other selected HC species	Unregulated	On line Mass Spectrometry (OLMS)
Particle Number	Unregulated	Condensation Particle Counter (CPC)
Mass Weighted Size Distribution	Unregulated	Micro Orifice Uniform Deposit Impactor (MOUDI)

Regulated emissions were collected in a single bag over the hot phase of the 97/24/EC cycle. Continuous raw and dilute logged data were recorded throughout the test. The mass emissions figures quoted are averaged across the triplicate set of 97/24/EC tests for each bike.

An important part of this test program is the collection of particulate matter. This is not a regulatory requirement at present, but if this was to be introduced for motorcycles, specific particulate sample handling equipment would be required for this purpose. Particulate mass measurement. The adaptation to the Ricardo Motorcycle emissions CVS system, to allow the collection of particulate matter, was carried out using as a guideline the automotive regulation 70/220/EC, Annex III. Main components required include; suitable CVS tunnel, particulate probe, particulate filter holders (to accommodate sample and back-up filters) and a sample handling system to withdraw a dilute exhaust sample from the CVS tunnel. In order to condition and accurately weigh the particulate matter a temperature and humidity controlled weighing facility is required. This is also detailed within regulation 70/220/EC.

5. COMPARATIVE EMISSIONS DATA

Limitations of Drive Cycle - The 97/24/EC cycle is a hot start, low speed light load cycle with a maximum speed of 50km/h, and a theoretical test distance of 4km. For small capacity vehicles (up to approximately 250cc), the drive cycle provides reasonably representative speed and loads, but for larger capacity machines the road speeds, rate of acceleration and throttle openings required are so low as to make the cycle very difficult to drive. Additionally, the engine is always operating in areas of poor combustion and driveability. This is totally unrepresentative of actual road use, and the drive profile is artificial and does not contain any normal road transient characteristics.

Test Bikes - Of the 12 bikes tested, 10 machines were 4-stroke, with capacities ranging from 125cc to 1300cc (1-4 cylinders), and 2 were 50cc single cylinder 2-stroke machines. The analysis carried out below is based on trends established from the 4-stroke data primarily, with comments/comparisons for the 2-stroke data discussed separately as appropriate.

The analysis method used was to review the overall mass emission data for the 12 bikes over the test cycle to establish overall trends, and then, where appropriate, to look in detail at relevant second by second data to aid in the understanding of a particular trend or characteristic. The second by second data used for this purpose includes dilute emissions and air fuel ratio, calculated from emissions data. These data are all included within this report.

BK05, although tested, was found to have a very variable fueling setting, and hence emissions trends varied considerably. After some discussion with relevant parties, it was considered that this bike had a possible fault with the fuel injection system, and hence is excluded from the analysis below, despite the results being included in the graphs for completeness.

Comparisons of mass emissions levels and fuel consumption data for the 12 bikes tested are shown in the Figures 21 to 26 below. Fundamental comparisons between individual engine types, cylinder capacity or number of cylinders are not possible due to the different emission control systems fitted to each vehicle. Comparisons are therefore based on tailpipe levels only.

5.1 Total Hydrocarbons

Figure 21 : HYDROCARBON EMISSIONS

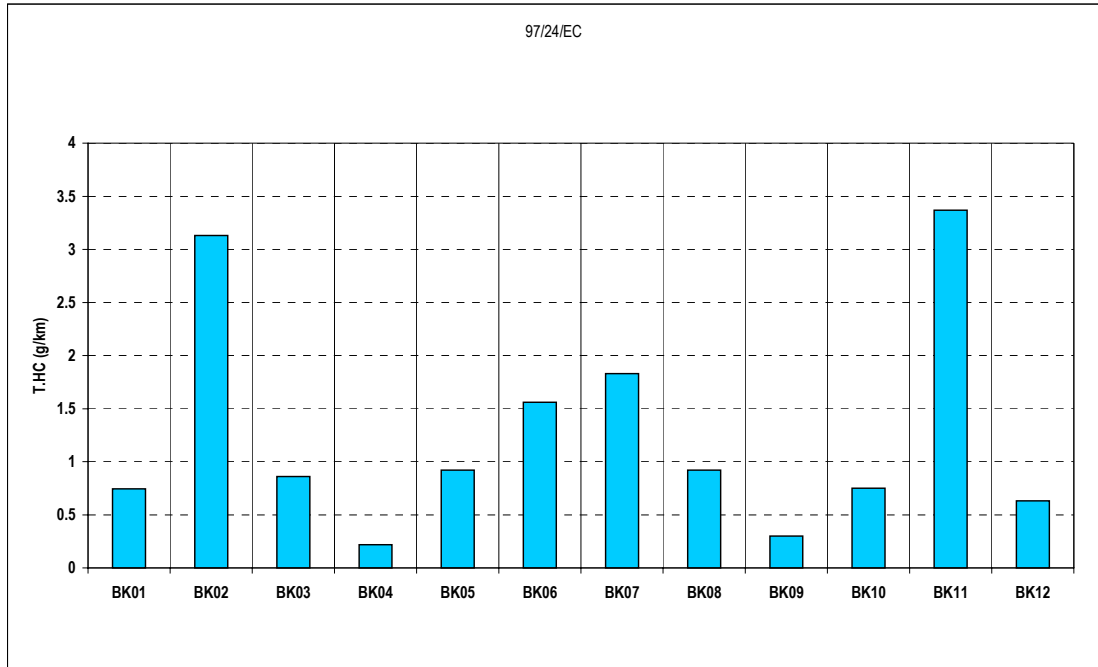

For the 4-stroke machines, BK02 shows exceptionally high HC levels over the 97/24/EC cycle. Analysis of second by second data shows levels dominated by deceleration HC, probably as a result of the simple slide type carburetor used on this vehicle giving high unburned fuel loss on the overrun. The cycle mass levels are typically 3-4 times those normally expected from a 4-stroke engine over the current legislated cycle. This vehicle fails Euro 1 on HC with a mass emission rate of 3.2g/km, despite having secondary air injection fitted.

The other 4-stroke machines show generally similar HC levels being in the range 0.5-1.0g/km. BK06 and 07 are the only other 4-stroke machines which exceed 1.0g/km. Second by second data for BK07 shows a very similar emissions trace to that of BK02, where deceleration HC dominates the overall cycle levels.

For the 2-stroke machines, BK11 has high HC emissions (3.4g/km) as a result of high levels of unburnt fuel in the exhaust, typical of a carburetted 2-stroke engine with no emission control features. By comparison, BK08 with direct fuel injection gives HC levels similar to the 4-stroke machines, showing how effective this technology is for 2-stroke HC emission control.

5.2 Carbon Monoxide

Figure 22 : CARBON MONOXIDE EMISSIONS

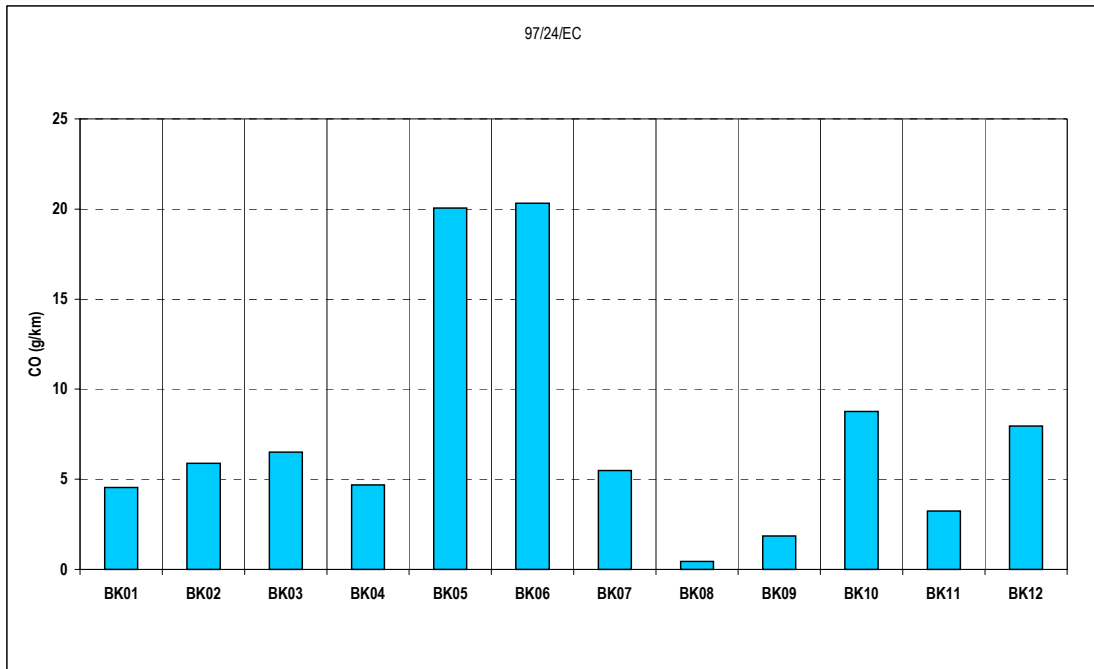

The 4-stroke machines generally showed CO emissions in the range of 2 to 9g/km. The exception to this was BK06 which had CO emissions on 20g/km, which exceeds the EURO I limit of 13g/km.

For the 2-stroke machines, BK08 has exceptionally low CO as a result of the very lean AFR possible with a direct injection system, at around 30-40:1 at part load and 20-25:1 at full load. The carburetted 2-stroke engine in BK11 produces similar levels to the 4-stroke machines.

5.3 Oxides of Nitrogen

BK03, 04 and 09 give good NO_x control indicating 3 way catalyst operation. These bikes gave typically 0.05 g/km against a current NO_x limit of 0.3 g/km.

BK06 and 07 have low engine out NO_x levels at around 0.1 g/km as a result of a richer fueling calibration as indicated by the CO levels. This gives lower combustion temperatures which reduces NO_x formation. This NO_x/CO relationship can also be seen for other vehicles, particularly BK01 and BK02, which show higher NO_x and lower CO.

BK10 and 12 have NO_x emissions towards the higher end of the range for the 4-stroke machines, due to the fact that these are air cooled machines which will typically run at higher cylinder temperatures than the water cooled machines, leading to higher NO_x.

Figure 23 : OXIDES OF NITROGEN EMISSIONS

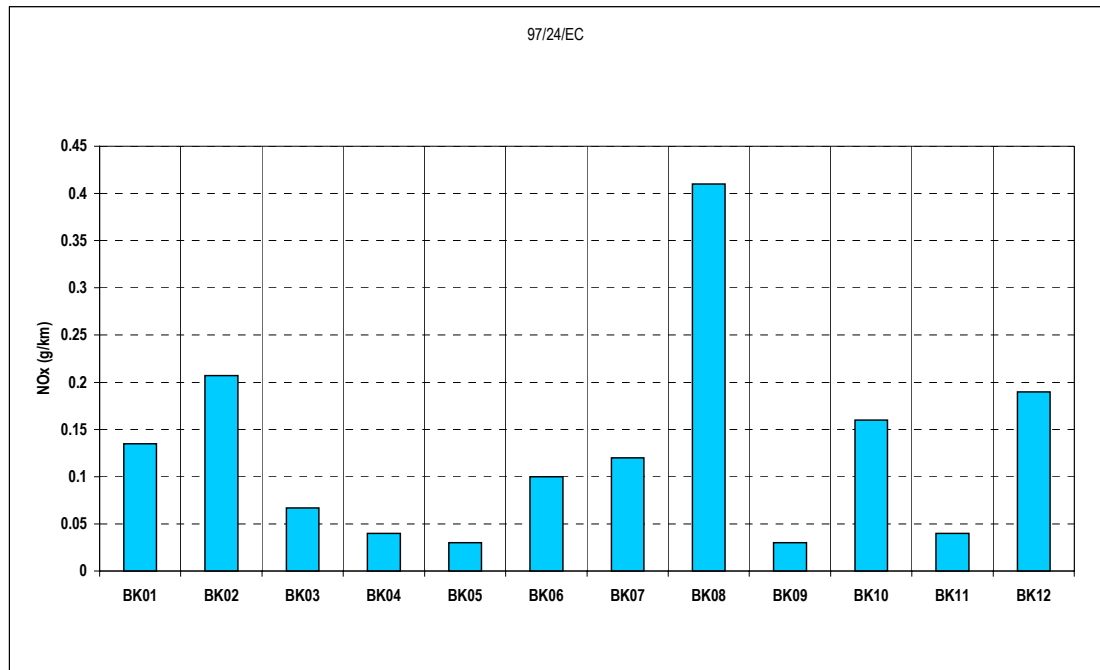

Carburetted 2-stroke engines have inherently low NO_x due to high levels of natural internal EGR, and low combustion temperatures and pressures. BK11 indicates this trend in comparison to the 4-stroke machines, with levels of ~0.04g/km. The other 2-stroke machine, BK08, produces the highest NO_x levels of any machine at around 0.41g/km. This is a result of the direct injection combustion system which effectively eliminates the internal EGR described above which gives the carburetted 2-stroke low NO_x. The use of direct injection on 2-strokes therefore is shown to shift the emissions problem from HC to NO_x. As the direct injection engine runs so lean, a conventional oxidation catalyst cannot be used to reduce NO_x levels, and hence control of NO_x will be a major future issue for the direct injection 2-stroke engine.

5.4 CO₂ and Fuel Economy

CO₂ and fuel consumption are discussed together for the purposes of this analysis as there is a fundamental link between the two.

Trends evident are primarily a function of engine capacity/vehicle mass. This is illustrated by the lower capacity vehicles giving lower CO₂ emissions and better fuel economy than the larger machines. In addition, CO₂ levels can be influenced by catalyst conversion efficiency.

The 2 stroke machines follow the same trends described above. BK08, with direct injection, gives fuel economy levels about 25% better than BK11 as a result of reduced fuel charge loss.

Figure 24 : CARBON DIOXIDE EMISSIONS

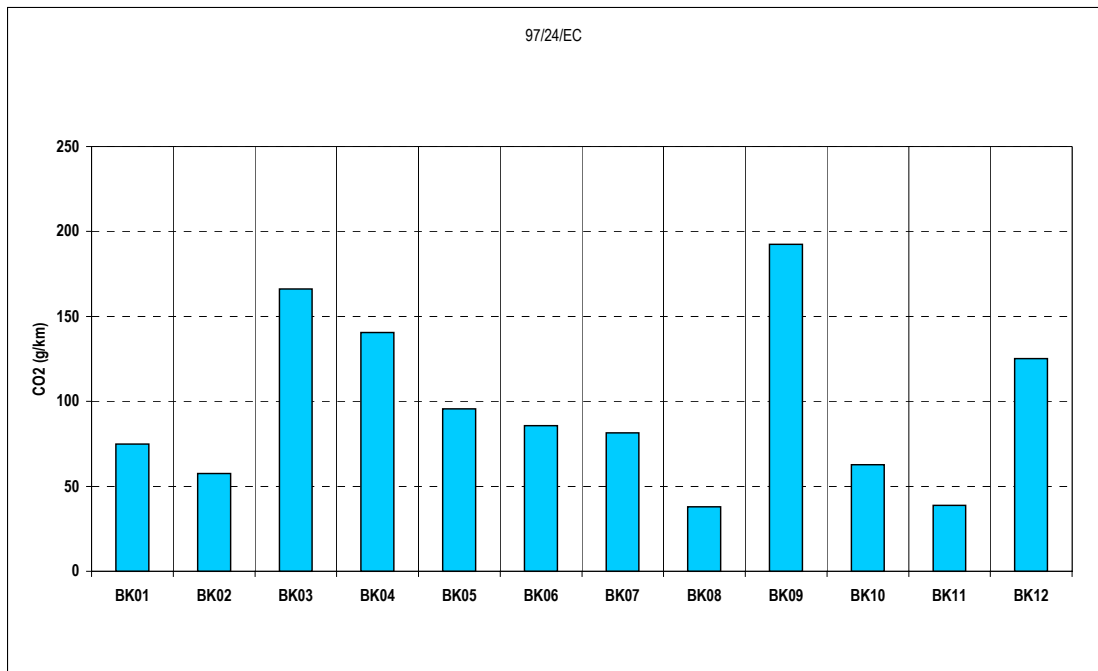
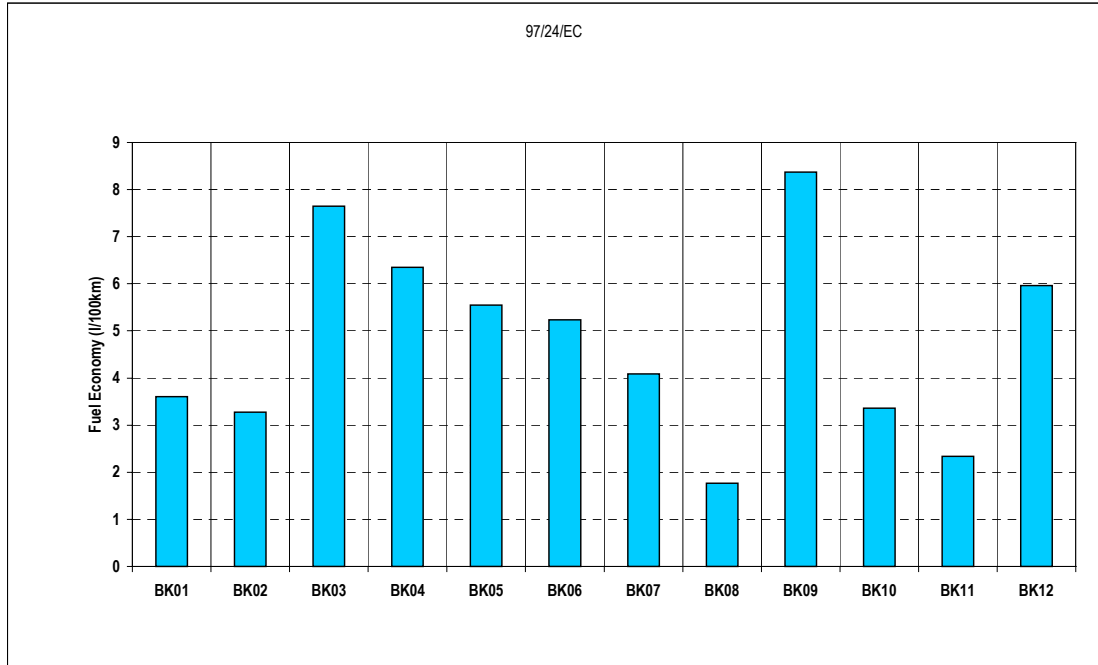
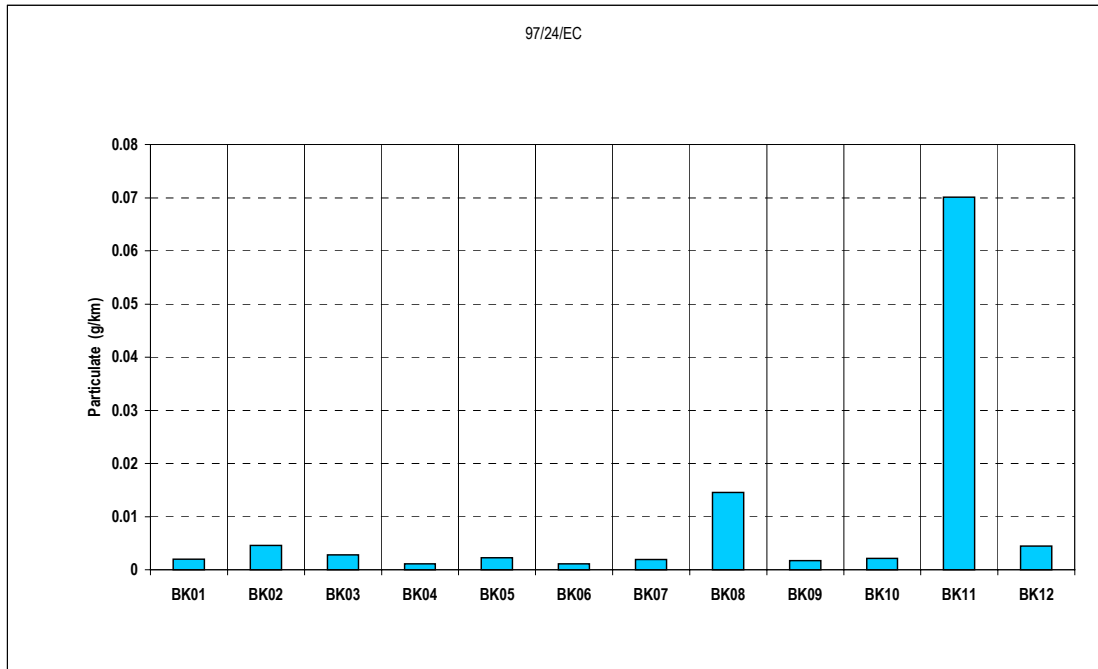

Figure 25 : FUEL ECONOMY



5.5 Particulates

Figure 26 : PARTICULATE MASS EMISSIONS



All 4-stroke particulate levels are relatively low at around 0.002-0.006 g/km, this is well below the Euro 4 passenger diesel car limit of 0.025 g/km. Whilst particulate mass is not routinely measured from gasoline cars, Ricardo limited experience is that mass emissions over the 98/69/EC cycle are < 0.001 g/km.

BK11 produces very high particulate levels in comparison to the 4-strokes at 0.07g/km. BK08 with direct injection produces levels of ~0.015g/km. This suggests that the direct injection system produces particulate levels far lower than those of a standard carburetted 2-stroke engine. Examination of the particulate filters for BK11 indicates that a high proportion of the particulate mass is oil-derived.

6 CONCLUSIONS

Twelve bikes have been successfully tested to the agreed test protocol and analysis of regulated emissions and particulate mass emissions has been conducted.

Testing of BK05 revealed some anomalous emissions data and this bike has therefore been excluded from the analysis.

Hydrocarbon emissions proved relatively consistent for the 4 stroke machines at ~30% or less of the current 97/24/EC limits. 2 bikes gave high HC levels over the 97/24/EC cycle due to excessive overrun HC levels. The carburetted 2 stroke machine gave HC levels of 3.4g/km and would need an improved exhaust catalyst system with secondary air to meet the current limits. The direct injection 2 stroke machine gave HC levels comparable to a 4 stroke.



CO emissions proved highly dependent on fuelling calibration and engine size/power.

Bikes with closed loop EFi and catalysts gave very good control of NO_x over the 97/24/EC cycle. The carburetted 2-stroke machine produced the lowest levels of NO_x, the direct injection machine the highest. The use of direct injection has been shown to shift the 2- stroke emissions problem from HC to NO_x, which will be a significant challenge for future legislation conformity.

CO₂ and fuel consumption increased with increased engine size and vehicle weight.

No real trends in PM emissions were observed between bikes. However emissions levels from all 4-stroke bikes were very low (0.001g/km to 0.013g/km). The carburetted 2-stroke bike produced very high PM levels compared to the other machines at 0.07g/km. Examination of the particulate filters showed a high proportion of oil derived mass from this bike.

Appendix 3 : Fuel Specification

UK Ultra Low Sulphur Gasoline

PROPERTY	UNIT	MIN	RESULT	MAX	TEST METHOD
Research Octane N°			97.2		D 2699
Motor Octane N°			89.2		D 2700
RVP @37.8 °C	Kpa		55.3		D 323
Distillation					D 86
E 70°C	%		18.8		
E 100°C	%		48.1		
E 150°C	%		91.1		
E 180°C	%		98.8		
Final Boiling Pt	°C		181.1		
Residue			1.2		
Hydrocarbon content					D1319
Aromatics	% vol		23.6		
Olefins	% vol		4.0		
Saturates	% vol		72.4		
Total Aromatics	% vol		28.8		IP391
Mono Aromatics	% vol		28.7		
Di Aromatics	% vol		0.1		
Tri + Aromatics	% vol		<0.1		
Oxidation stability	Minutes		>960		D 525
Benzene content	% vol		0.80		GC analysis
Lead content	g/l		<0.002		IP 228
Sulphur content	mg/kg		22		D3120
Density @ 15°C	kg/l		0.734		ISO 3675
Carbon content	%		86.0		D5291
Hydrogen content	%		14.0		D5291
H/C Ratio			1.95:1		
Calorific value	Btu/lb		18771		GC analysis

References:

- 1 "The health impact of urban pollution: present needs and future challenge", European Council of Applied Sciences and engineering.
- 2 "Options to Reduce Nitrous Oxide Emissions (Final Report), November1998", <http://europa.eu.int/comm/environment>
- 3 Environmental Protection Agency web site, <http://www.epa.gov/ghginfo/>
- 4 Opinion expressed at the 24th CSTE E plenary meeting, Brussels, 12 June 2001
- 5 "International Environmental Technology Volume II Issue 2 May/June 2001"
- 6 http://europa.eu.int/eur-lex/en/dat/2001/l_309/l_30920011127en00220030.pdf